



DES PDM 24 CLEAN



Cable entry plate for Food&Pharma applications

NEW

- ▶ For large number cables without connectors
- ▶ Internal reinforcing frame
- ▶ Rounded edges
- ▶ UL94V0 self extinguishing
- ▶ Fixing with threaded inserts
- ▶ IP66 / Nema 4X

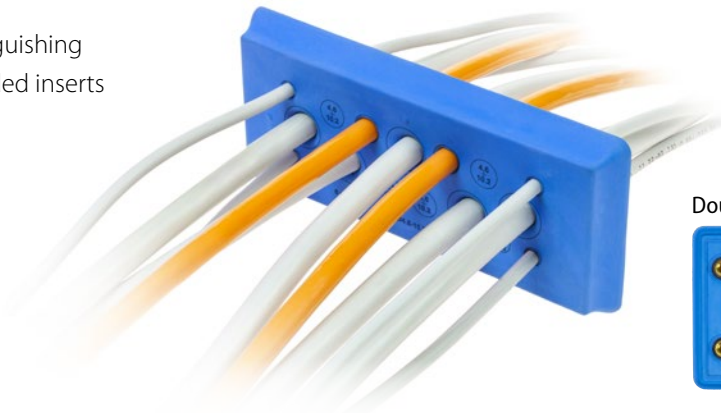

Double parallel membrane

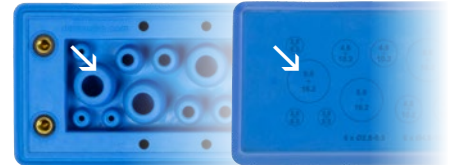

Model	Code	Cable nr. - Ø cable min/max [mm]	Dimensions [mm]		Pcs /pack
			Cut-out	Plate	
DES PDM 24/17 CLEAN	1732025017	6 - 2,8 / 6,5 6 - 4,6 / 10,2 5 - 8,6 / 16,2	112 x 36	155 x 66	1

The DES PDM 24 CLEAN family is mainly used in the food&pharma production chain thanks to the rounded shape without edges which avoids dirt accumulation and allows frequent washing.

Fixing takes place through hidden threaded inserts that ensure perfect stability of the plate even after countless washes.

The holes location is guided by a laser printing which guarantees the front clean area during the operation.

The first front membrane is lightly drilled with a small screwdriver, while the second parallel membrane acts as a reinforcement, ensuring a very high strain relief and water resistance.

Technical data

Material: TPE

Flammability: self-extinguishing acc. to UL94-V0

Temperature: -40°C... +105°C (static)

Features: halogens and silicones free

Related products

Hydraulic punch driver HY360

Plugs IFP

FVM metal detachable cable ties

2

Dimensions [mm]

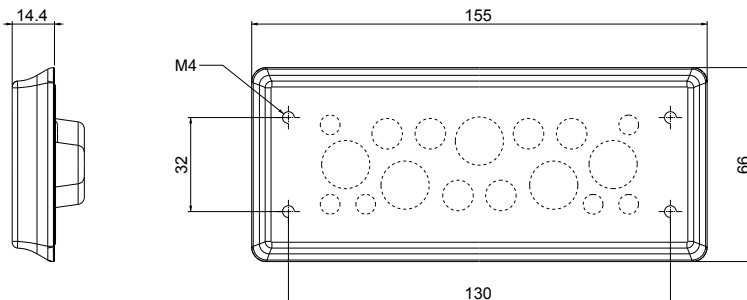

IP66

NEMA 4X

NEMA 12



ECOLAB

UL94-V0



RoHS COMPLIANT



+105
-40
°C