

# UK6C/H1-1EUL

cylindrical ultrasonic



Micro Detectors

Italian Sensors Technology



Indicative image

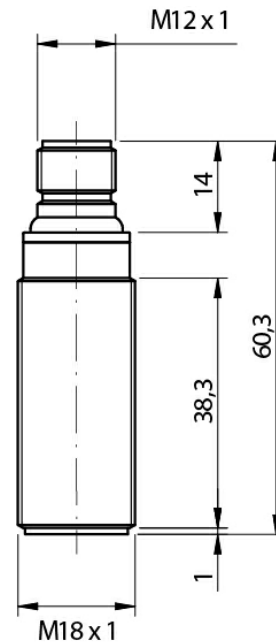

## Detection properties

Nominal sensing distance	800mm
Thermal drift of Sr	≤2%
Repeat Accuracy	0,50%
Beam angle	8° ± 2°
Resolution	≤3mm
Sensitivity adjustment	Teach-in by wire
Hysteresis	1%
thermal compensation	Yes
Minimum sensing distance (blind zone)	60mm
Linearity error	1%

## Outputs

Output type	analogue output 0...10v
Switching frequency	5Hz
Response time	500ms

## Electrical data

Operating Voltage	10 - 30Vdc
-------------------	------------

No-Load supply current	≤35mA @Val = 30V
Load current	100mA
Leakage current	10µA @ 30Vcc
Output voltage drop	2,2Vmax. @ IL=100 mA
Max ripple content	5%
LED indicators	green: echo - yellow: output
Time delay before availability	≤300ms
Short-circuit protection	Yes
Reverse Polarity Protection	Yes
Impulsive Overvoltage Protection	Yes
Minimum load resistance	3kΩ

## Mechanical data

Dimensions	M18 x 1 / L = 60,3mm
Weight	80g
Housing Material	stainless steel AISI 316L
Connections	M12 Plug
Tightening torque	50Nm
Operating temperature	- 20°C...+ 70°C
Storage temperature	- 35°C...+ 80° C without freeze
Transducer Frequency	230kHz

## Test/Approvals

Approvals	CE cULus
EMC compatibility	IEC 60947-5-2
Shocks and vibrations	IEC EN60947-5-2 / 7.4
Degree of protection	IP67

## Accessories

Supplied Accessories	2 nuts M18x1, 2 washers Ø 18
----------------------	------------------------------

# ELECTRICAL DIAGRAMS OF THE CONNECTIONS

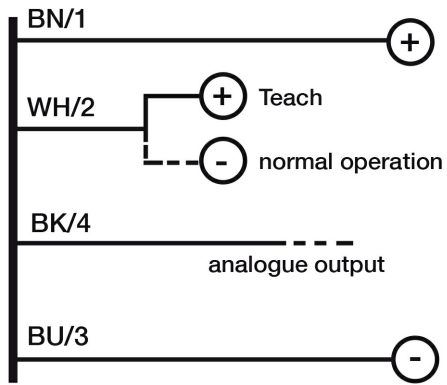

## CONNECTOR

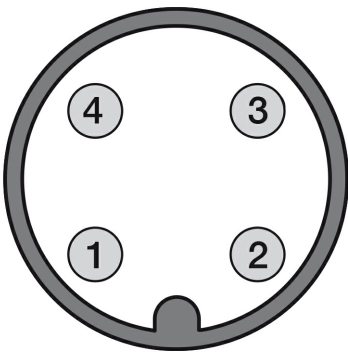

## RESPONSE CURVES

### Disassamento Parallelo

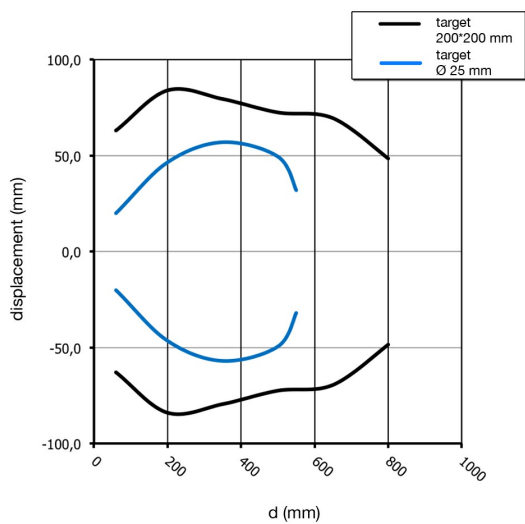

Strada S.Caterina, 235  
41122 Modena (MO)  
Tel. 059 420411  
Fax 059 253973  
E-mail [info@microdetectors.com](mailto:info@microdetectors.com)

23/07/2019 13:37:55