

# FARP/BP-0E

cylindrical photosensors



Micro Detectors

Italian Sensors Technology



Indicative image

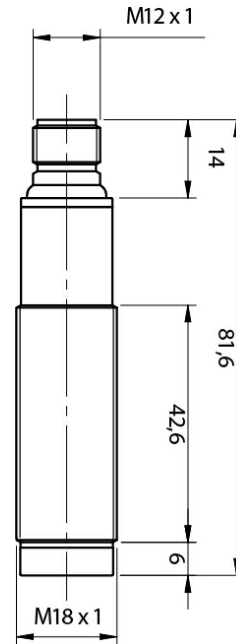

## Detection properties

Nominal sensing distance	4m with RL110
Thermal drift of Sr	≤10% Sr
Repeat Accuracy	5%
Sensitivity adjustment	No

## Application

Function Principle	Polarized
Optic position	Axial

## Outputs

Output type	PNP
Output Function	NO+NC
Switching frequency	250Hz

## Electrical data

Operating Voltage	10...30Vdc
No-Load supply current	≤30mA
Load current	≤100mA
Leakage current	≤10μA

Output voltage drop	2V max. IL =100 mA
Max ripple content	10%
LED indicators	Yellow (output state)
Time delay before availability	≤200ms
Short-circuit protection	Short circuit (autoreset), Overvoltage
Reverse Polarity Protection	Polarity inversal, Impulsive voltage
Emission	Red (660 nm)
Interference to external light	5000lux (incandescent lamp), 10000lux (sunlight)

## Mechanical data

Dimensions	M18 x 1 /L =81,6mm
Weight	30g
Housing Material	PBT / PC plug
Connections	M12 plug
Active Head Material	PMMA
Tightening torque	1Nm
Operating temperature	- 25°C...+ 70° C (Without freeze)
Diameter/Dimension	M18

## Test/Approvals

Approvals	CE, cULus
EMC compatibility	EN 60947-5-2
Shocks and vibrations	Vibration IEC 60068-2-6 / Shock IEC 60068-2-27
Degree of protection	IP67

## Accessories

Supplied Accessories	nuts M18 x 1
----------------------	--------------

---

# ELECTRICAL DIAGRAMS OF THE CONNECTIONS

---

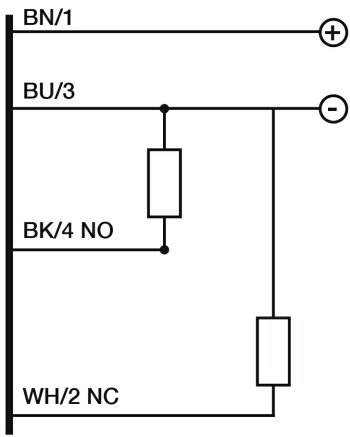

## CONNECTOR

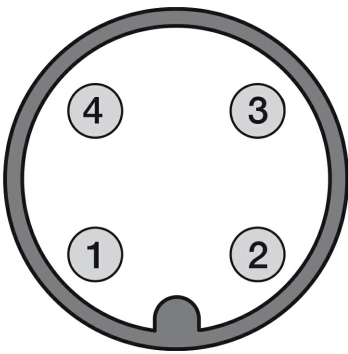

## RESPONSE CURVES

### Dimensione Spot

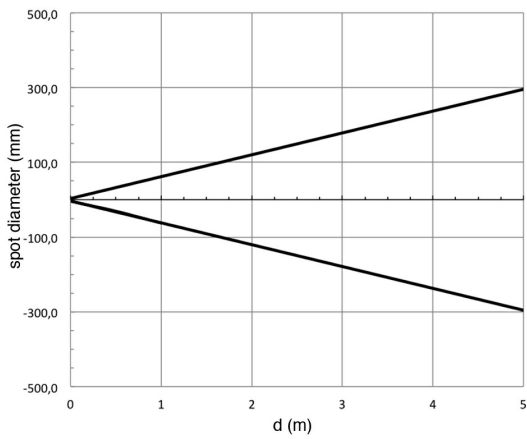

### Disassamento Parallelo

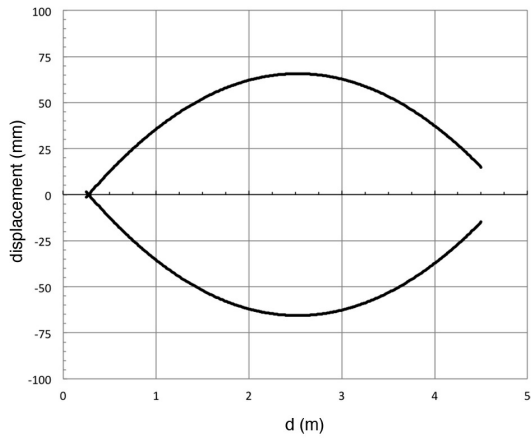

## Eccesso di Guadagno

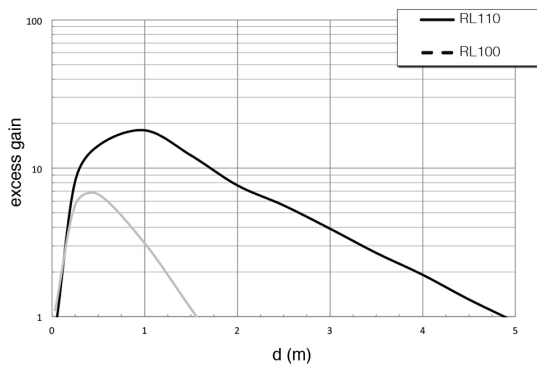

**M.D. Micro Detectors S.p.A.**

Strada S. Caterina, 235

41122 Modena (MO)

Tel. 059 420411

Fax 059 253973

E-mail [info@microdetectors.com](mailto:info@microdetectors.com)

**date of printing**

14/04/2020 16:54:34