

VITECTOR

FRABA



Safety Systems for Industrial Applications

TABLE OF CONTENT

Products		Opto-electronic safety edge – OSE	
Product Overview	3	OSE-Sensor	32
Safety edges		OPC-Sensors	34
Principles of Operation	6	OPTOCORD-Modules	39
Opto-electronic safety edge – OSE		Control Units	48
General function	7	Overview profiles	67
Advantages of the OSE	8	Overview accessories	82
The components	10	Pneumatic Switches -DW	
Installation of the OSE	12	Pneumatic switches - DW	91
Pneumatic switch – DW		Signal Source	95
Function	14	Pneumatic switch - accessories	97
Components	14	RAYTECTOR	
Advantages of the DW	15	Product descriptions	101
Installation	16	Range of applications	102
Application areas of safety edges		Electrical connection	104
Main closing edge of a rolling gate	18	Technical data RAYTECTOR	106
Main closing edge of a folding gate	19	Flashentry	
Safeguarding door on a machine	20	Product description	108
Closing edge of a train door	21	Range of application	109
Standards and Directives		Attaching the FLASHENTRY unit	111
Safety category	23	Technical data FLASHENTRY	113
DIN EN 1760 - 2	24	Entrysense	
Din EN 954 - 1	25	Product description	114
Standards governing doors and gates	27	Technical data	115
Certificates		Contacts	
Certified systems	28	Contact Person	116

Copyright

Copyright to the documentation is held by VITECTOR GmbH. No part of this documentation may be modified, extended, duplicated or passed on to third parties without the prior written consent of Messrs. VITECTOR GmbH.

Changes

We reserve the right to change the technical information at any time in accordance with our constant efforts to improve our products. All details are without obligation, since mistakes and printing errors cannot be excluded.

PRODUCT OVERVIEW

Product Overview



Opto-electronic safety edge – OSE

- High safety
- Approved by the German employers' liability insurance association (BG) and the UL
- Assembly by the user
- Modular system design
- High system reliability

Pneumatic switch – DW

- Assembly by the user
- Modular system design
- Low cost
- High flexibility of the signaling unit

Function	7
Technical data	33

Function	14
Technical data	92



PRODUCT OVERVIEW



RAYTECTOR

- Pull-in protection according to EN 12453
- OSE-compatible interface
- Simple assembly and adjusting

Function	101
Technical data	106



FLASHENTRY

- compatible to most radio systems
- Simple assembly and adjusting

Function	108
Technical data	113



ENTRYSENSE

- Safe wicket door switch according EN 12453-1
- normal closed contact, testable
- Simple assembly and adjusting

Function	114
Technical data	115

PRODUCT OVERVIEW

Applications

Safety edges are used wherever moving edges pose a hazard to people. The hazardous areas are protected by hollow rubber profiles. As soon as a person or object touches them, the sensing profile is deformed and the potentially hazardous movement halted.

Safety edges are used in a variety of applications in mechanical and plant engineering. Their uses range from automatic gates, safety hoods on machines auto-guided vehicle systems through lifting tables to front loading industrial style washing machines.

Requirements

The safety edges must meet a variety of requirements in these very different application areas. These requirements can be classified in three groups, as follows:

Safety

The safety requirements to be met by the safety edges are determined through a hazard analysis and risk assessment. The safety edges must also be approved by a certification agency.

Reliability

Non-operational safety facilities result in machine downtimes and have a major influence on the work flow. High availability of the system used is therefore absolutely essential. In addition, the safety edge must also be resistant to ambient influences, such as moisture, dirt, vibrations and corrosive media.

Cost efficiency

Customers benefit from the simple installation, short delivery times and simple logistics.

Mechanical design of a safety edge

As defined by the standards, a safety edge comprises three elements: the signaling element, signal processing and signal output.

Signaling element (Sensor)

The signaling element is the pressure-sensitive part of the safety edge and generates a signal when the actuating force is exceeded through contact with a person or object. The signaling element is linear in shape and is locally deformed when actuated.

Signal processing (Control Unit)

The signal generated by the signaling element is analyzed by the signal processor and controls the signal output.

Signal output device

The signal output device generates the control command (normally a Stop command) for the higher-ranking machine control which halts the potentially hazardous movement.

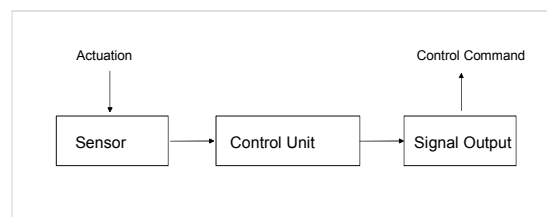

OPTO-ELECTRONIC SAFETY EDGE – OSE

Principles of Operation

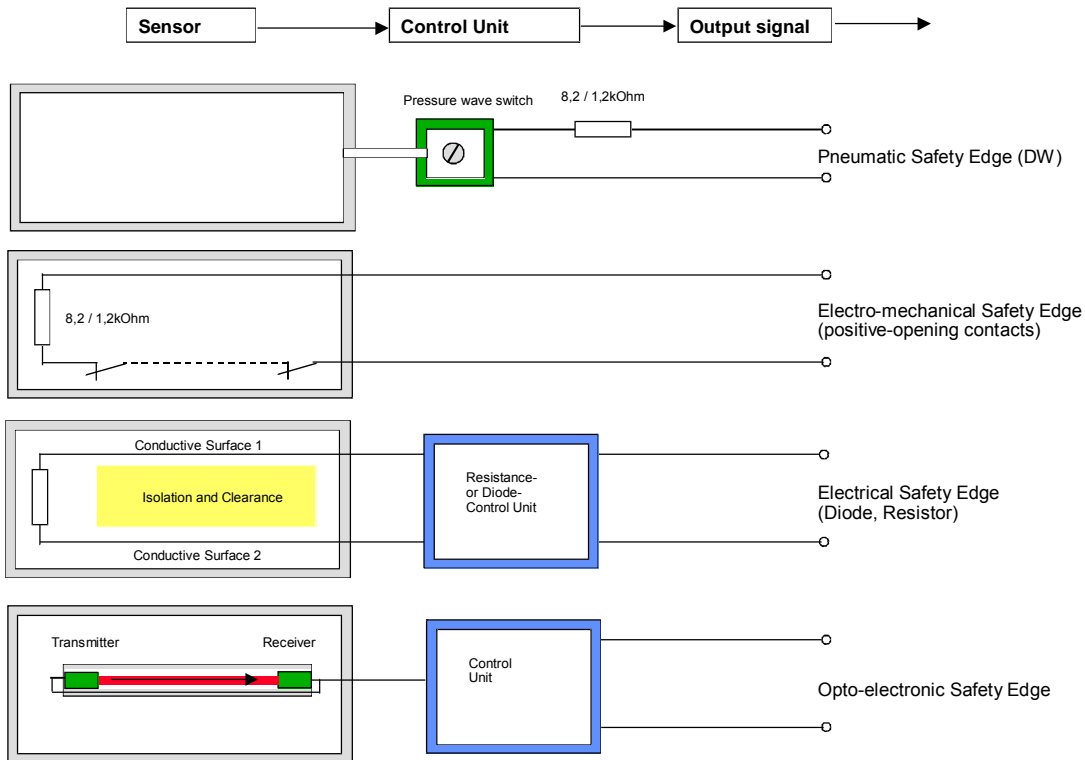

Pneumatic switch

Actuation of the signaling element generates a pressure wave which is detected by the pressure-wave switch – normally via a diaphragm. This diaphragm converts the pressure wave into an electrical signal which can be processed by the higher-ranking control system.

Electrical safety edge

The signaling element of an electrical safety edge comprises two non-insulated electric conductors which are kept at a predetermined distance by the mechanical design of the signaling element. The two conductors contact one another when the safety edge is deformed.

Electromechanical safety edge

The signaling element in this case comprises a series of positive-opening contacts. When actuated, the contacts open locally and interrupt the flow of current.

Opto-electronic safety edge

A safety light barrier is installed in the rubber profile of the opto-electronic safety edge (OSE). The light beam is interrupted when the signaling element is actuated.

OPTO-ELECTRONIC SAFETY EDGE – OSE

General function

The opto-electronic safety edge OSE is comprised of an infrared safety light barrier enclosed in a hollow rubber profile. When the hollow rubber profile is deformed, the optical channel is interrupted, causing a dynamic safety signal to fail. This is detected by the control unit which interrupts the enable circuit. The potentially hazardous movement is halted.

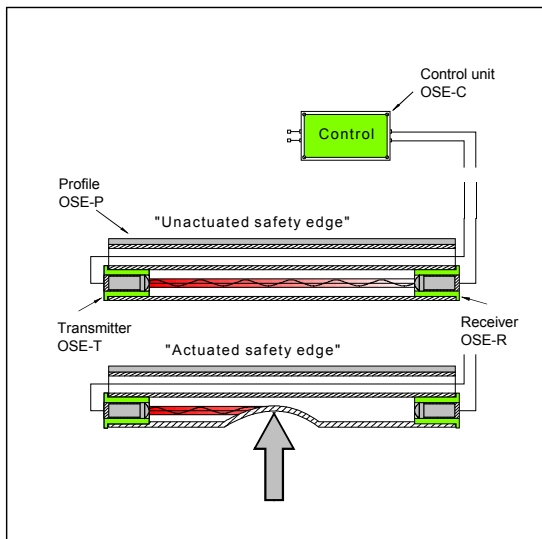

The OSE does not require direct visual contact between transmitter and receiver. Since the infrared light beam is reflected by the surface of the rubber profile, operation of the safety edge is not affected by minor bending due, for instance, to wind loads. Major bending or compression of the optical channel, on the other hand, attenuate the light so strongly that the safety edge switches off reliably.

Principle of operation

The system is exceedingly fail-safe, as because its intelligence has been integrated directly into the sensors.

It is imperative that interruption of the light beam, effects due to extraneous light and faults in the electrical components (including the connection to the control unit) must be detected reliably.

Integrity of the system is ensured by optically and electrically connecting the transmitter-receiver system. The transmitter sends out infrared light pulses which are detected by the receiver. The latter includes several input filters to suppress extraneous light. As soon as transmitter light is detected, the receiver deactivates the transmitter via the signal line and the flow of light ceases. This condition is similarly detected by the receiver and the transmitter is reactivated after a given delay. The result is a dynamic signal which is analyzed by the control unit.

Every fault in the transmitter-receiver system results in failure of the dynamic signal, since either the optical or the electrical signal has been affected.

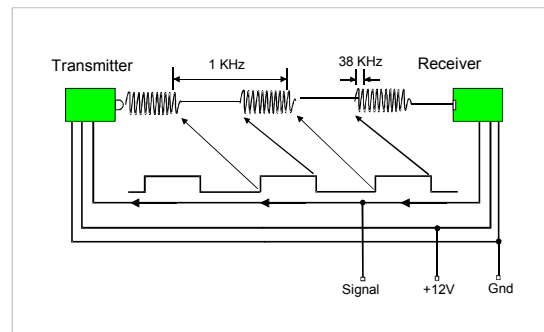

The safety category of the OSE essentially depends on the control unit, which analyses the reliable dynamic transmitter-receiver signal and sends the resultant status signal to the output unit.

OPTO-ELECTRONIC SAFETY EDGE – OSE

Advantages of the OSE

The advanced technology of the OSE yields a number of advantages:

- Simple assembly
- High safety
- High environmental stability
- High flexibility.

For the customer, this not only means lower costs, but also very high reliability and ready for availability of the safety edge.

Assembly

The OSE can be installed very simply and easily (refer also to page 13). Single components can be exchanged very easily. The aluminum rail and the rubber profile are supplied as endless sections which are cut to the required length. Transmitter and receiver are then inserted into the rubber profile and wired to the electronic control unit. It is not necessary to bond or preassemble the components.

The simplicity with which the rails can be assembled yields the following advantages:

Neither technical know-how nor special tools are required to install the safety edge

The quality of the safety edge does not depend on its assembly

The system can be installed without difficulty directly on site

Short delivery times

Simple logistics and cost-efficient stock keeping

Lower production costs.

The design also yields advantages if a defect should arise:

The safety edge can be replaced immediately during the technician's first visit. Repairs are therefore quick and inexpensive.

Because defects in the safety edge are usually limited to the rubber profile, the OSE can be replaced quickly and easily keeping repair costs low and down time to a minimum.

Machine downtimes and gate stoppages can be minimized.

Safety

The high safety and reliability of the OSE is due to the dynamic transmitter-receiver concept.

Approved by the employers' liability insurance associations (BG) up to safety category 4 as defined by DIN EN 954-1.

- Broken wires and short-circuits are detected in the coiled cable (and in the transmitter / receiver leads).
- All deviations from the normal operating condition are detected.
- The system is self monitoring. Defects are detected in advance of accidents.

Environmental stability

The system's electronic components (transmitter and receiver) are completely enclosed in a special sealing compound assuring the protection of an IP 68 enclosure. This gives the sensor element of the safety edge the following properties:

- Total resistance to moisture
- High resistance to weathering and aging
- High mechanical stability
- Large temperature range
- High resistance to weathering and aging

OPTO-ELECTRONIC SAFETY EDGE – OSE

- High mechanical stability
- Large temperature range performance
-

The intelligence of the safety edge is located in the transmitter and receiver:

- Simple interface to the control unit can easily be integrated into the gate control
- Automatic adjustment of the transmitter power in accordance with the length of the safety edge
- Compensation of any aging phenomena in the rubber profiles
- Moisture and dirt in the profile can be compensated within limits
- Complex integrated receiver circuit ensures extensive resistance to extraneous light
- No sensitive lines to the control system and therefore no problems as regards EMC
- Connecting lines to the sensors can be up to 200 meters long.

The completely sealed sensors are located at the ends of the safety edge.

- The part of the safety edge that is most susceptible to vandalism is comprised of a rubber profile for which standard materials are used (sulphur-crosslinked EPDM)
- Operation is not affected by minor damage to the rubber

Flexibility

- The ease with which the safety edge can be assembled gives the user or engineer great flexibility allowing for extensive variability in planning.

- Existing profiles can be used if suitable (dependent upon geometry and material).
- The rubber profile can be produced to the customer's specific requirements. This permits a large variety of profile shapes (folding gates, high-speed gates, etc.) while keeping profile and tool costs low.

Disadvantages of the OSE

- Due to the dynamic principle, individual safety edges cannot be directly connected in series. Several control units or a multi-control unit must be used in this case.
- Angles greater than 30° normally cannot be realized by bending the rubber profile, as the light will be attenuated too strongly. Two safety edges should be installed in this case.

OPTO-ELECTRONIC SAFETY EDGE – OSE

The components

The simple modular design of the OSE system allows users to install the safety edge themselves. Only a few components are required and can be combined into a perfectly functioning safety edge without requiring any special tools or technical know-how.

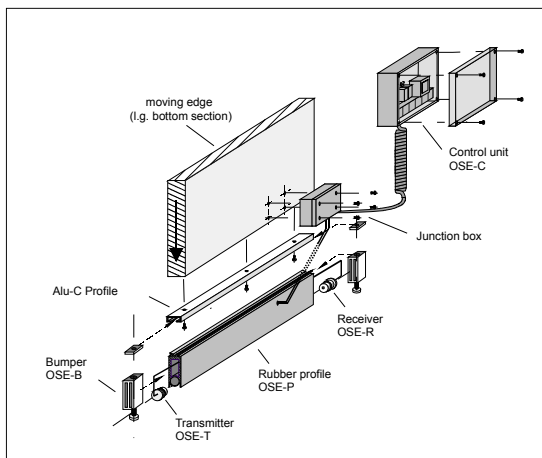

Sensors

The sensors (transmitter and receiver) are shaped like conventional profiled end plugs. The electronics are completely sealed in the housing to ensure high resistance to such ambient influences as water, dust and moisture. Their type of protection corresponds to IP 68.

Two different versions are available with diameters of 22 mm or 11 mm.

Transmitter

The transmitter generates a pulsed infrared signal, the strength of which is automatically adjusted in line with the length of the safety edge. This guarantees optimum sensitivity and high availability at all times. The transmitter includes a self-learning function and can therefore compensate for the effects of aging in electronic components or the

profile, as well as minor deformation caused by damage to the door leaf. This further enhances the availability of the safety edge.



Receiver

The receiver responds to failure of the dynamic IR light beam by generating an error message which is detected by the control unit and causes the potentially hazardous movement to be halted. Use of an integrated receiver component ensures high security against extraneous light.

Rubber profile

The rubber profile has two chambers. Transmitter and receiver are inserted in the round upper chamber. The shiny interior of this chamber resulting from the production process ensures that the infrared light travels from transmitter to receiver by reflection on the inner walls. Slight bends in the profile can consequently be tolerated without difficulty. When the profile is deformed beyond the specified limits, the optical channel is interrupted and the enable circuits open in the control unit. At the ends of the safety edge the transmitter and receiver protrude into the lower chamber, thus ensuring that the light beam is interrupted. The actuation forces at the ends are higher, resulting in dead surfaces according to DIN EN 1760-2.

OPTO-ELECTRONIC SAFETY EDGE – OSE

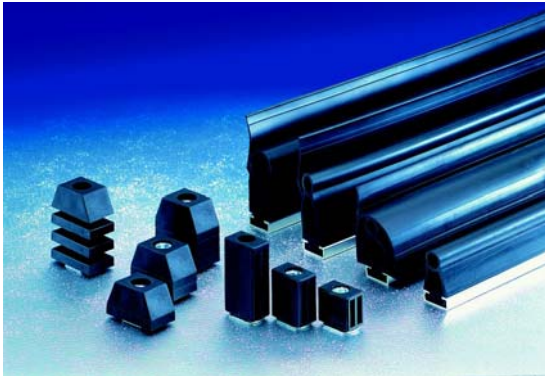

Since the transmitter is effectively self-controlled, the actuation- and the over travel are effectively independent of the profile length. These parameters are consequently determined by the speed of the gate and the shape of the profile. The product range already includes a large variety of profile shapes. Customized profiles can be produced quickly and at low costs.

Provided that the inner surface of the round chamber is smooth and shiny, a customer's own profiles can be used in addition to those presented here.

Control unit

The signal from the transmitter-receiver system is analyzed by the control unit in accordance with DIN EN 954-1. A number of versions are available, from category 1 to the highest category 4. The OSE consequently meets the safety requirements for all possible safety edge applications.

The control unit is available with various plastic housings – for installation in a control cabinet or for surface-mounted installation. Plug-in cards for several gate control systems are also available for applications involving doors and gates.

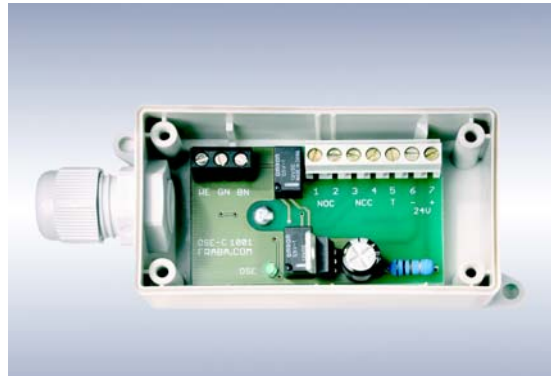

Since the signal interface between transmitter and receiver is well documented, the control unit can also be integrated into the gate control system. In this case, the sensors can be connected directly to the terminals provided for this purpose. A current list of control systems is available on request.

Accessories

Our range of products includes comprehensive accessories for installation of the opto-electronic safety edge OSE.



OPTO-ELECTRONIC SAFETY EDGE – OSE

Installation of the OSE

Installation of the opto-electronic safety edge (any installed position) is a simple matter. Proceed as follows:

1. Attachment of the signaling element

The ALU-2509 rail is meant for attaching the safety profile. You have to drill holes into the aluminum rail in ~ 70 mm distance and to fix it to the application with the use of oval head or countersunk head screws (\varnothing 3 - 6 mm). The surface should be plain and clean. The aluminum rail must be assembled with lengths over 2.50 m from several pieces. Ensure that neither misalignment nor bends occur.

Slide or clip the sensor profile into the rail mount. If mounted vertically, the profile has to be fixed to avoid slipping off the Alu-C-rail.

2. Connection of the Signal transmission device

The cables of the sensors are interconnected in a suitable box and connected to the signal transmission device (for example a coiled cable).

3. Connection of the Control unit

The signal transmission device, voltage supply and the output signal switching devices are connected according to the specification of the operation instructions of the respective control unit.

4. Test of the Safety Edge

After installation and electrical connection of the safety edge, the components used must be noted in the installation log.

Perform required test as outlined in the inspection log.

The safety edge can be installed directly on site, because special tools and adhesives are not required. The mechanical assembly should be executed by a skilled employee, the electrical connections by an electrical specialist.

Regular maintenance of the machine, function and condition of the safety edge should be checked by a specialist (for example experts for gates).

Warning note

Before beginning the installation, the user information and the operating instructions must be read completely. The entire security of the machine depends on the quality, the reliability and the correct connections of the interfaces.

Replacement of individual components

The replacement of individual components of the safety edge is simple and can be executed directly on site. All components can be replaced by the user, if he is a skilled employee.



OPTO-ELECTRONIC SAFETY EDGE – OSE

Replacement of the signaling element

1. First cut the rubber profile OSE-P and the associated aluminum mounting rail to the required length.
2. The transmitter and receiver are then inserted into the hollow chamber. The sensors are already firmly seated to ensure they cannot be removed without difficulty. They can be inserted into the chamber more easily if wetted with a little water or spirit.
3. The transmitter lead is pulled through the second chamber to the receiver side with the aid of a pull-in wire.



4. The rubber profile is then drawn or clipped into the mounting rail or directly into the gate panel. It must be secured so that it cannot drop out if it is installed vertically.
5. The sensors are interconnected in the junction box and then connected to the control unit via a lead (such as a coiled cable) or they are connected directly to the control unit. The electrical connections should be done by an electrically skilled person.

Installation of accessories

It is advisable to fit two stoppers at the ends of the safety edge to protect the sensors when used in gate applications. However, these stoppers must not be mounted inside the clear width of the gate.

Beginning of operation

Upon start up of operation or replacement of components the safety edge should be tested, to determine if the installation was correctly performed and if the electrical connections are correct.

Verify the following:

- Optical control of the components and examination of the attachments
- Wiring based on the connecting diagrams
- Nominal dates of all inputs and outputs
- Optical control: does the signaling element cover the complete dangerous area with its sensitive surfaces
- Actuation of the signaling element at several positions with stopped machine. Verification of the LED in the control unit. The sensitivity of the safety edge should be equal over the entire effective sensing area
- Actuation of the signaling element under operation. Verification of a system stop. Restart should not be possible, until the safety function is recreated.

PNEUMATIC SWITCH – DW

Function

Pressure-wave switches are electro-pneumatic converters which convert a positive or negative pressure wave into an electrical contact or pulse. Actuation of the pressure-wave source generates a pressure wave which is transformed into an electrical pulse by a diaphragm inside the pressure-wave switch. If the switch is designed with normally open contact, the diaphragm contact will press against the contact screw and thus make electrical contact. In the case of a normally closed contact, the closed contact opens when the diaphragm is deformed.

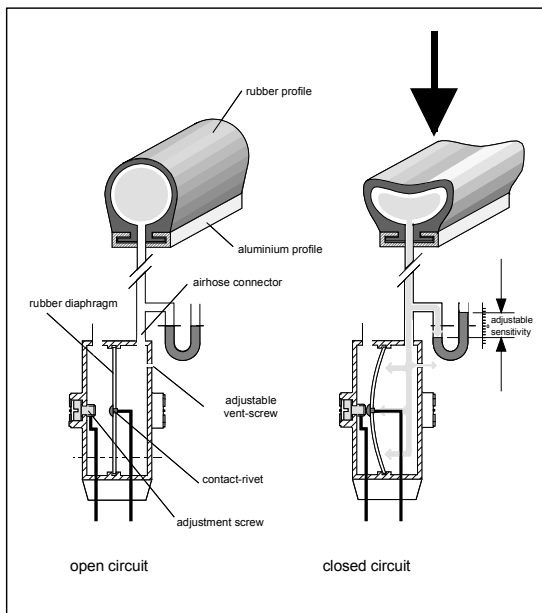

Contact is made briefly, since the pressure wave escapes through an adjustable valve opening in the pressure-wave switch. This valve ensures that the volume of air in the signaling element is balanced in order to avoid erroneous triggering. Transient changes in air volume may be caused by changes in atmospheric pressure or temperature fluctuations, and are of no consequence.

Components

The pressure-wave switch is the most important component in the system. The pressure-wave source can take many different forms.

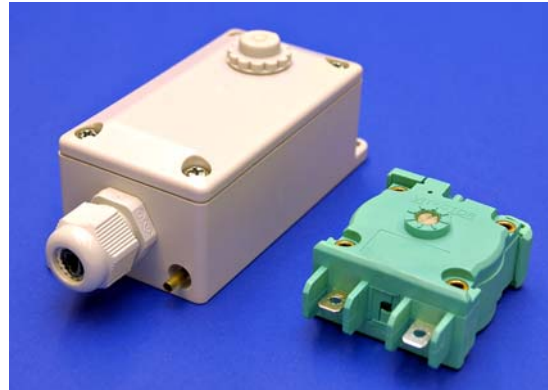

Pressure-wave switch

The FRABA DW delivers a NC, NO or change-over contact signal which is tapped via screw or plug-in terminals. It can be mounted in a variety of external housings with up to IP 65 of protection. The sensitivity of the switch can be set with great precision over a large range by adjusting the screw and valve opening.

Pressure-wave source

Any object which changes its volume under pressure and thus generates a positive or negative pressure wave can be used as the pressure-wave source. Our range includes a variety of sources.

Accessories

Our range of products includes appropriate, comprehensive accessories for installing the DW.

PNEUMATIC SWITCH – DW

Advantages of the DW

The tried-and-tested technology of pneumatic switches yields the following advantages:

- Low costs
- Simple assembly
- High flexibility
- Low actuating forces and short travel.

Low costs

Both the pressure-wave source and the pressure-wave switch are very cost-efficient.

Simple assembly

The pneumatic switch can be installed simply and easily. The aluminum rail and the rubber profile are supplied as endless sections which are simply cut to the required length. Connecting and end stoppers are inserted in the rubber profile and connected to the pressure-wave switch via a signal hose. It is not necessary to bond or preassemble the components.

The simplicity with which the switch can be assembled yields the following advantages:

- Neither technical know-how nor special tools are required to install the switch.
- The quality of the switch does not depend on its assembly.
- The system can be installed without difficulty directly on site.
- Short delivery times.
- Simple logistics and cost-efficient stock keeping.
- Lower production costs.

The design also yields advantages if a defect should arise:

- The switch can be replaced immediately during a technician's visit. The system can therefore be repaired quickly.
- It is usually the middle part of the assembly that is damaged when a defect arises. In the case of the pneumatic switch, the handy rubber profile is located in the middle part and can be replaced without difficulty, thus keeping repair costs low.
- Machine downtimes and gate stoppages can be minimized.

High flexibility

- The ease with which the switch can be assembled gives the user or engineer great flexibility and therefore permits extensive variability in the planning.
- Existing profiles can be used if suitable (chamber diameter and material).
- Complex forms can be realized (circles, almost any bending radii).
- The variable and cost-efficient pressure-wave sources (door protection and ground contact profiles, etc.) permit a variety of possible uses and forms.

Disadvantage of the DW

- One disadvantage of the pneumatic switch is that the system is not self-monitoring. A defective switch, for instance, is not detected by the system itself.
- Category 2 to DIN EN 954-1 can be achieved with external testing.

PNEUMATIC SWITCH – DW

Installation

Installation of the pneumatic switch (any installed position) is a simple matter. Proceed as follows:

1. First cut the rubber profile and the associated aluminum mounting rail to the required length.
2. Plug the ends of the profile with the end or connecting stoppers.
3. Connect the air port on the pressure-wave switch to that of the connecting stopper via a signal hose.
4. Connect the electrical contacts of the pressure-wave switch to the higher-ranking control system.

Counterclockwise = Greater sensitivity

Clockwise = Lower sensitivity

- Normally closed contact

Counterclockwise = Greater sensitivity

Clockwise = Lower sensitivity

- Changeover contact

NC side (marked W):

Counterclockwise = Greater sensitivity

Clockwise = Lower sensitivity

- NO side (unmarked):

Counterclockwise = Greater sensitivity

Clockwise = Lower sensitivity

Drawing

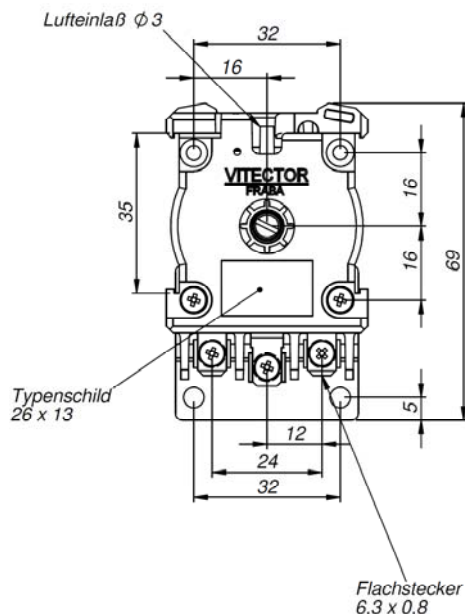

The same contact function can be obtained by using suction instead of pressure after changing over the hose connection.

Conversion instructions

Normally open to normally closed

1. Change over hose connection.
2. Connect buzzer or test lamp.
3. Screw relief valve into other side.
4. Turn plastic adjusting screw clockwise until contact makes; then continue turning until required setting is obtained (approx. 4 scale divisions).

Normally closed to normally open

1. Change over hose connection.
2. Connect buzzer or test lamp.
3. Screw relief valve into other side.
4. Turn plastic adjustment screw counterclockwise until contact opens, then continue turning until required setting is obtained (approx. 4 scale divisions).

Adjustment instructions

The sensitivity can be adjusted by turning the plastic adjustment screw on the switch. The relief valve must not be adjusted.

- Normally open contact

APPLICATION EXAMPLES

Application areas for safety edges

Safety edges are used wherever moving edges jeopardize the safety of persons or objects. The hazardous edges are protected by a hollow rubber profile. The safety edge is deformed when it is touched, thus triggering a signal which causes the potentially hazardous movement to be stopped.

Safety edges are to be found in a large variety of applications. These can be subdivided into three groups:

Doors and gates

European standards require that edges on automatically operated doors and gates which could pose a crushing hazard must not exceed a specified force when they strike an obstacle. Safety edges are almost always used to safeguard such potentially dangerous points.

The standard governs not only industrial gates, but also the automatically operated gates on private grounds.



Vehicle construction

Defined forces must similarly not be exceeded when automatically closing doors on buses or trains come into contact with passengers. Here,

too, safety edges can help to ensure greater safety.

Further applications are to be found in the automatically closing doors and windows of motor cars, trucks and special-purpose vehicles.



Mechanical and plant engineering

The variety of application areas is particularly large in the field of mechanical and plant engineering:

- Protective hoods and doors on machines (partitioning safety mechanisms)
- Auto-guided vehicle systems
- Lifting tables and hoisting platforms
- Automatic manipulators (robots, material)
- Washing-plants and -portals

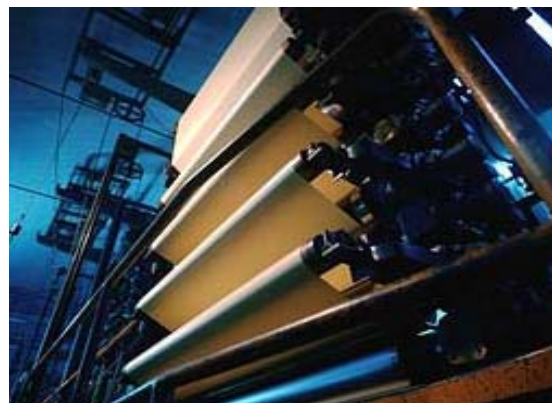

APPLICATION EXAMPLES

Main closing edge of a rolling gate

Application examples

A rolling gate is to be converted to automatic operation. European standards require that the main closing edge must be safeguarded. The standard method is to install a safety edge.



1. Profile

A suitable profile must first be selected. The most important criterion here is the over travel of the profile. The over travel specified by the manufacturer must be greater than the stopping path of the gate. The geometry of the profile is the second most important aspect and must be adapted to the gate panel.

The standard rolling gate profile OSE-P 25 75 01 is a suitable profile for this application, as its over travel is sufficient for the majority of rolling gates and it also features the required geometry. The aluminum rail ALU-2509 is used as mounting rail.

2. Sensors and control unit

The choice of control unit depends on the gate control system used. Since many control systems can analyze the sensor signals directly, a simple

reversing-contactor control is used here. This in turn requires the use of an external control unit for the safety edge. The OSE-C 2323 meets with the requirements.

Sensor types OSE-R 1100 and OSE-T 1100 must be used, as the profile has an 11 mm chamber.

3. Accessories

End stoppers should be used to protect the safety edge in its lower limit position. These stoppers must not be fitted inside the clear gate width. Type OSE-B 5518 stoppers are suitable for this profile.

The sensors are connected in the junction box (AC 1101) on the gate and connected to the control unit via a three-wire coiled cable (AC 1000).

4. Connection to the gate control system

The Stop signal for the safety edge must interrupt the self-holding function of the gate. The gate may only be operated in dead-man mode if the safety edge does not work.

The gate must be reversed when the signal to rise is given. In the lower limit position, the rise signal from the safety edge should be interrupted via a pre-limit switch, otherwise the gate could be opened by actuation of the limit position.

5. Adjustment of the limit switches

The limit switches must be re-adjusted as a result of using the safety edge. The sensing chamber should not be crushed in the limit position.

APPLICATION EXAMPLES

Main closing edge of a folding gate

Application

A safety edge is to be installed on each door leaf to safeguard the main closing edge of a folding gate.



1. Profile

A suitable profile must be selected. When determining the appropriate profile, the over travel and actuating angle must be considered. Since the profile rarely knocks against the obstacle centrally in the case of a folding gate, it must be possible to actuate the safety edge from an angle.

Because the profile is almost always mounted directly on the door's main closing edge FRABA VITECTOR includes a variety of customized solutions.

2. Sensors and control unit

The choice of control unit depends on the gate control system used. Many control systems can analyze the sensor signals directly. In this case, however, two edges must be controlled. The control unit OSE-C 2323 can be used here in accordance with the new standard.

Most profiles have an 11 mm chamber, so that the sensor types OSE-R 1100 and OSE-T 1100 must be selected here. The exact length of the sensor wiring depends on the wiring of the door leaf. For some applications, it may be advisable to use sensors with wiring suitable for inclusion in energy guiding chains.

3. Accessories

End stoppers are not required. The sensor wiring is usually routed via energy guiding chains.

4. Connection to the gate control system

The Stop signal from the safety edge must interrupt the self-holding function of the gate. The gate may only be operated in dead-man mode if the safety edge does not work.

The gate must be reversed when the signal to re-open is given. In the closed position, the re-open signal from the safety edge should be interrupted via pre-set limit switches, otherwise the gate could be opened by actuation in the limit position.

APPLICATION EXAMPLES

Safeguarding door on a machine

Application

A lightweight safety door covering an industrial washing machine must be safeguarded.

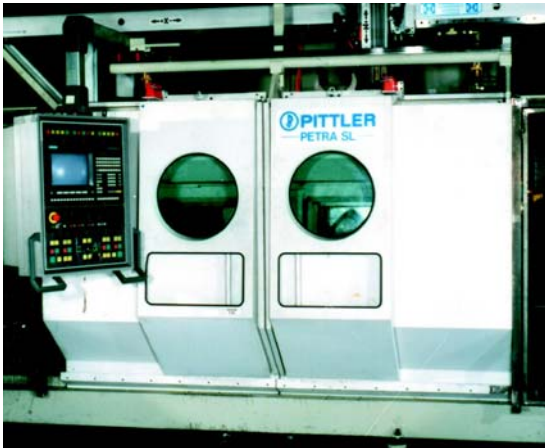

1. Risk analysis

The risk posed by this protective door must first be analyzed. In this case, the safety edge is merely required to protect the operator from the door as it closes automatically. Safe limit switches are used to determine whether the door is closed and the machine can start operation.

Due to the weight of the door and torque of the drive motor, only minor injuries can be sustained and category 1 to DIN EN 954-1 will consequently suffice.

2. Profile

The user must now select a suitable profile. The over travel of the profile is the most important

criteria. The over travel specified by the manufacturer must be greater than the stopping path of the door.

The profile OSE-P 25 30 00 is the most suitable for this application, as it features sufficient over travel and the appropriate geometry. The aluminum rail ALU-2509 is used as a mounting rail.

3. Sensors and control unit

The choice of control unit depends on the risk analysis. Since category 1 is required, the control unit OSE-C 4524 can be used here.

The profile has an 11 mm chamber; sensor types OSE-R 1100 and OSE-T 1100 must therefore be used.

4. Accessories

The sensors are connected in the junction box (AC 1101) on the door and connected via a three-wire lead to the control unit installed in a control cabinet approx. 20 m away.

5. Connection to the control system

The Stop signal of the safety edge is looped into the safety circuit of the machine control and stops the door if actuated. Optionally the Monitoring signal is connected to the machine control.

6. Adjustment of the limit switches

The limit switches must be re-adjusted as a result of using the safety edge. The sensing chamber should not be crushed in the limit position.

APPLICATION EXAMPLES

Closing edge of a train door

Application

The turning-folding door of a passenger train must be safeguarded via a safety edge.



1. Profile

A suitable profile must first be selected. A special profile is required for this application. The profile geometry must ensure sufficient over travel, actuation from the side and correctly seal the door even at high speeds.

Specific standards must also be taken into account with regard to the material.

2. Sensors and control unit

The profile has an 11 mm chamber to minimize the actuating path; sensor types OSE-R 1101 and OSE-T 1103 must therefore be used.

Since the sensors are wired directly in the door leaf, the sensor leads are sufficiently long and there is no need to use wiring suitable for energy guiding chains.

The sensor signals are analyzed directly by the door control. The sensors can therefore be connected directly to the control system via a three-wire lead.

3. Integration into the customer's control system

Since the sensor signal is simple and well documented, it can easily be analyzed directly in the higher-ranking control system. If a microprocessor is available, it can be used to analyze the signal. The only additional requirements are an input filter and a power supply for the sensors. Further information about the dynamic sensor signal is available upon request.

APPLICABLE STANDARDS AND DIRECTIVES

Directives

Safety edges are governed by the European Directive on machine safety. In addition, they must also meet the requirements pursuant to the EC Directives on electromagnetic compatibility (EMC) and low-voltage installations.

The manufacturer of the products confirms, in the Declaration of Conformity, that his products comply with the requirements imposed by these Directives.

Machinery directive	98/37/EG
Low-voltage directive	73/23/EWG
EMC directives and alterations as well as the directives on radio equipment and telecommunications terminal equipment (R&TTE directive)	89/336/EWG, 91/263/EWG, 92/31/EWG, 93/68/EWG, 93/97/EWG

In the case of some machinery and safety components which are defined in Annex IV to the Directive, conformity cannot be certified by the manufacturer alone, but must be undertaken by a duly authorized test institute.

Safety edges are one of the products defined in this Annex. Their conformity must therefore be tested and certified by the Employers' Liability Insurance Association (BG) or the Technical Control Board (TÜV).

Relevant standards

Harmonized standards apply in all countries of the European Union and EFTA. They are drawn up at a European level by the standardization institutions CEN and CENELEC. Compliance with the standards is not mandatory, but machines and accessories which are designed and built or produced in accordance with the standards are most likely to

comply with the Directives.

A / B / C standards

The harmonized standards are subdivided into three groups:

- A-standards deal with aspects affecting all types of machine.
- B-standards relate primarily to safety products and secondarily to the safety-related aspects of mechanical engineering.
- C-standards are product standards governing a specific type of machine.

Conformity with the relevant Directives is assured if products are designed and built in accordance with the applicable product standards. If C-standards are not available for a particular application, the relevant A and B standards must be observed.

Safety edges and standards

The requirements to be met by safety edges are set out in the harmonized standard DIN EN 1760-2. This is a B-standard and therefore serves as the basis for development of the safety edges produced by FRABA VITECTOR. C-standards are also available for some products, such as doors and gates.

EN 1760-2	Safety of machinery, pressure sensitive protective devices. General principles for the design and testing of pressure sensitive edges and pressure sensitive bars
-----------	--

Focal points of the standards and their significance when selecting a safety edge are described on the following pages.

SELECTION OF A SAFETY EDGE

The signaling element of a safety edge is normally used to safeguard a point at which people or objects may be trapped or crushed or which poses a collision risk. It must be ensured that the movement is reliably halted in all applications and that the maximum permissible forces acting on a person are never exceeded when the safety edge is tripped.

The most important parameters for selecting a suitable safety edge are the required safety category DIN EN 954-1, the speed of the potentially hazardous movement, the stopping path of the parts causing the hazard and the specific profile data of the safety edge.

Safety category

DIN EN 954-1 specifies five categories defining the requirements to be met by the safety-related parts of the control systems.

The applicable category is determined by assessing the risk for a particular application. If a product standard exists, it already defines the requirements to be met.

Limitation of the forces occurring

The force acting on a person or object depends on several factors. The permissible forces depend on which part of the body is exposed to the risk. These are defined in type C standards and must correspond with the risk assessment.

The stopping path of the parts causing the hazard

must be determined first. When a Stop command is given by the safety device, the control system and braking system require a certain time in order to bring the movement to a complete halt. The stopping path is consequently determined by the speed of the movement, the response time of the control system and the efficacy of the braking system. It should therefore be measured under the worst possible conditions conceivable.

The minimum over travel required by the safety edge is determined from the measured or given stopping path at maximum operating speed. The standard DIN EN 1760-2 mentions multiplication with a safety factor of at least 1.2.

If the application involves extremely frequent actuation, care should be taken to choose a signaling element that recovers its original shape as quickly as possible.

Attention must also be paid to the construction of the opposite edge.

Choice of equipment

When the stopping path and speed are known, the force-travel diagrams of the safety edges can be used to select the safety device with the required over travel and the required operating speed.

The stopping response of the machine may have to be improved if a device with sufficient over travel cannot be found.

DIN EN 1760 - 2

DIN EN 1760 - 2

DIN EN 1760 is a B-standard governing protective devices which detect the presence of a body or parts of the body through the pressures and forces exerted on them.

DIN EN 1760-2 defines the general principles for designing and testing pressure sensitive edges and bars. Part 1 of the standard deals with safety mats and panels, while part 3 is concerned with bumpers, ripcords and similar protective devices.

Safety edges - definition

A safety edge is a mechanically actuated protective mechanism with approximation response (as defined by EN ISO 12100-1) which is designed to detect contact with a person or part of the body. It comprises a pressure-sensitive signaling element and the signal processing, which processes the signals from the signaling element and generates an output signal for the machine control system.

Actuating surfaces

The signaling element of a safety edge can be locally deformed and can be used to detect everything from a finger to the complete body. The effective sensing surface is defined in the data sheets; insensitive zones are permitted. The actuating surfaces and angles must be described in the data sheets.

Safety

Safety edges must meet the requirements of category 1, 2, 3 or 4 as defined by DIN EN 954-1.

Force-travel diagrams

The actuating forces and pre-travel, the over travel and the total working travel are plotted in a force-travel diagram for each safety edge.

The maximum actuating forces are specified in the standard. For detecting fingers, for example, they must remain below 50 N.

Ambient conditions

The standard defines the requirements to be met by the safety edges as a result of climatic conditions, EMC, vibrations and shock loads. They must be suitable for use in an industrial environment; the test conditions are also specified in detail.

Certification

Since safety edges are products governed by Annex IV of the Directive on machine safety, the system must be tested by an authorized test agency.

The safety edge can only be tested as a complete system comprising the signaling element, the signal processing and the output unit.

DIN EN 954 - 1

Din EN 954 - 1

























DIN EN 954-1 defines the general design principles for safety-related parts in control systems. It is a type B standard not related to any particular application and can be used as the basis for other standards governing machine safety. Both DIN EN 12453 and DIN EN 1760-2 refer to this standard in this context.

The central element of DIN EN 954-1 is its definition of five categories for safety-related parts in such protective devices as safety edges, for instance.

The requirements to be met for the respective categories are briefly summarized below (extract from the BIA Report 6/97).

Category B

Safety-related parts in control systems and/or their protective devices and components must be designed, built, selected, assembled and combined in accordance with the applicable standards and in such a way that they can withstand the influences to be expected.

How to find the correct category	Category				
	B	1	2	3	4
S1 →					
Start →					
P1 →					
F1 →					
P2 →					
S2 →					
P1 →					
F2 →					
P2 →					
<p>S: Severity of injury S1: Slight (normally reversible) injury S2: Serious (normally irreversible) injury, including death</p> <p>F: Frequency and duration of exposure F1: Seldom to more often and / or brief exposure duration F2: Frequent to continuous and / or long exposure duration</p> <p>P: Possibility of avoiding hazards P1: Possible under certain conditions P2: Hardly possible at all</p> <p> Preferred category  Additional measures required  Over - dimensioned category</p>					

Category 1

The requirements for B must be met. Established components and established safety principles must be used or applied.

Category 2

The requirements of B must be met and the application of established safety principles assured. The safety function must be checked by the machine control system at appropriate intervals.

Category 3

The requirements of B must be met and the application of established safety principles assured. Safety-related parts must be designed so that:

- a single fault in each of these parts does not result in loss of the safety function and,
- the individual fault can be detected wherever reasonable and possible.

Category 4

The requirements of B must be met and the application of established safety principles assured. Safety-related parts must be designed so that:

1. a single fault in each of these parts does not result in loss of the safety function and,
2. the individual fault is detected during or before the next requirement or, if this is not possible, an accumulation of faults must not result in loss of the safety function.

Examples

The BIA Report mentions the following applications by way of example:

Safeguarding the closing edge of motor-driven gates:

- Major and possibly fatal injuries may be caused: S2
- Persons rarely remain in the hazard area: F1
- The possibility of avoiding the hazard depends on the speed of the gate. P1 applies for gates which close at low speed, P2 for those which close at high speed.

This means that the protection for the closing edge must at least comply with category 2 (S2, F1, P1) or category 3 (S2, F1, P2).

This logically corresponds with the requirements of standard DIN EN 12453.

The following consideration applies in the case of an auto-guided vehicle system:

- Serious injuries may be sustained: S2
- The vehicle paths are freely accessible, so that people can be expected to be found in the hazard area relatively often: F2
- The vehicles normally travel slowly so that people can get out of their way: P1

Category 3 consequently applies with regard to the protection against collision with auto-guided vehicle systems.

FRABA systems

The safety edge systems supplied by FRABA VITECTOR meets the requirements of all safety categories:

Category	System
B	OSE, DW
1	OSE
2	OSE, DW
3	OSE
4	OSE

DIN EN 954 - 1

Standards governing doors and gates

Doors and gates must be built and operated in such a way that their use does not endanger people. This means that all hazard points must be avoided or safeguarded if this is not possible. The underlying principles are currently set out in the BG-Regulation governing power operated windows, doors and gates (BGR 232).

European standards

In conjunction with the harmonization of national rules and regulations in the European Community, a system of standards is currently being compiled which will replace the national regulations.

One of the most important changes is that there will be no differentiation between the types of use when applying European standards. All standards apply to both the private and the commercial sphere.

The regulations of the European standards will also cover all gates marketed from the date on which the respective standards come into force. The date on which they are marketed need not be the same as that on which the system is erected or commissioned. Retroactive inclusion of existing systems is not planned.

Three standards will apply with regard to ensuring safety in areas posing a crushing, shearing or trapping hazard:

- DIN EN 12453 – Industrial, commercial and garage doors and gates, Safety in use of power operated doors, requirements

- DIN EN 12445 Industrial, commercial and garage doors and gates, Safety in use of power operated doors, test methods
- DIN EN 12978 – Industrial, commercial and garage doors and gates, Safety devices for power operated doors, requirements and test methods

Where the requirements to be met by safety edges are concerned, these standards are based on the product standard 1760-2.

Compared with the former guidelines (ZH 1/494), considerably more stringent requirements now apply for the safety edges used.

Limitation of forces

The maximum force which may act upon an obstacle is defined with great precision and must not exceed 400 N (in exceptional cases 1400 N) over a short period of time (0.75 s). The force must subsequently decrease again. Finger detection is not required.

Safety

If this limitation of forces is realized by means of protective devices (normally safety edges), the latter must comply with category 2, 3 or 4 as defined by DIN EN 954-1.

CERTIFIED SAFETY EDGES

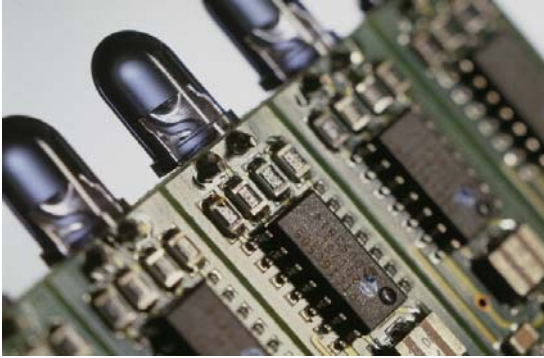

Certified systems

The following table summarizes the safety edges (signaling element and control unit) which are certified by the BG. The certificates are printed on the following pages.

Description	Transmitter	Receiver	Control Unit	Profile	ALU-C Rail	
OSE-1020	OSE-T 1100	OSE-R 1100	OSE-C 4524	OSE-P 25 30 00	ALU-2509	CAT. 1 24 V DC
OSE-1021	OSE-T 1100	OSE-R 1100	OSE-C 4524	OSE-P 25 33 00	ALU-2509	CAT. 1 24 V DC
OSE-1022	OSE-T 1100	OSE-R 1100	OSE-C 4524	OSE-P 30 58 00	ALU-3009	CAT. 1
OSE-1025	OSE-T 1100	OSE-R 1100	OSE-C 4524	OSE-P 30 90 01	ALU-3009	CAT. 1 24 V DC
OSE-3020	OSE-T 1100	OSE-R 1100	OSE-C 5024	OSE-P 25 30 00	ALU-2509	CAT. 3 24 V DC
OSE-3021	OSE-T 1100	OSE-R 1100	OSE-C 5024	OSE-P 25 33 00	ALU-2509	CAT. 3 24 V DC
OSE-3022	OSE-T 1100	OSE-R 1100	OSE-C 5024	OSE-P 30 58 00	ALU-3009	CAT. 3 24 V DC
OSE-3023	OSE-T 1100	OSE-R 1100	OSE-C 5024	OSE-P 25 90 00	ALU-2509	CAT. 3 24 V DC
OSE-3024	OSE-T 1100	OSE-R 1100	OSE-C 5024	OSE-P 20 40 01	ALU-2007	CAT. 3 24 V DC
OSE-3025	OSE-T 1100	OSE-R 1100	OSE-C 5024	OSE-P 30 90 01	ALU-3009	CAT. 3 24 V DC
OSE-4000	OSE-T 1100	OSE-R 1100	OSE-C 4024	OSE-P 25 30 00	ALU-2509	CAT. 4 24 V DC
OSE-4001	OSE-T 1100	OSE-R 1100	OSE-C 4024	OSE-P 25 33 00	ALU-2509	CAT. 4 24 V DC
OSE-4002	OSE-T 1100	OSE-R 1100	OSE-C 4024	OSE-P 30 58 00	ALU-3009	CAT. 4 24 V DC
OSE-4005	OSE-T 1100	OSE-R 1100	OSE-C 4024	OSE-P 30 90 01	ALU-3009	CAT. 4 24 V DC

OSE – CERTIFICATES

European notified body
Identification number 0340



Fachausschuss Elektrotechnik
Prüf- und Zertifizierungsstelle
im BG-PRÜFZERT

Hauptverband der gewerblichen
Berufsgenossenschaften

Translation

EC-Type Test Certificate

05158

no. of certificate

Name and address of the holder of the certificate: (customer) FRABA-VITECTOR GmbH
Schanzenstraße 35
51063 Köln

Name and address of the manufacturer: see customer

Ref. of customer:

Ref. of Testing and Certification Body:
23.520.28/02-16-263 Sto/Ow

Date of Issue:
28.06.2005

Product designation: Opto-electronic pressure sensitive edges

Type: OSE-1020; OSE-1021;
OSE-1022; OSE-1025

Intended purpose: In the temperature area of +5°C to +55°C.

Testing based on: 73/23/EEC "Low voltage directive"
89/336/EEC "EMC-directive"
DIN EN 1760-2 "Safety of machinery – Pressure sensitive protective devices
- Part 2: General principles for the design and testing of
pressure sensitive edges and pressure sensitive bars" (2001-07)

Remarks: The pressure sensitive edges fulfil the requirements of category 1 according to DIN EN 954-1 (1997-03).
The requirements according to section 4.23 to EN 1760-2 for OSE-1020 (21)(22) are in a sense fulfilled,
because the exceed of the limit will be balanced by the reduce of the follow-up distance.
Replacement to EC-Type-test-certificate ET 01110.

The type tested complies with the provisions laid down in the directive 98/37/EC (**Machinery**).

The present certificate will become invalid at the latest on:

31.12.2009

Further provisions concerning the validity, the extension of the validity and other conditions are laid down in the Rules of Procedure for Testing and Certification of April 2004.

Stommel

Dipl.-Ing. Stefan Stommel
Manager of the certification body

PZB02E
05.04



Postal address:
Postfach 51 05 80
50941 Köln

Office:
Gustav-Heinemann-Ufer 130
50968 Köln

Phone: 0221 / 3778 - 6301
Fax: 0221 / 3778 - 6322

In any case, the German original shall prevail.

OSE – CERTIFICATES

European notified body
Identification number 0340



Fachausschuss Elektrotechnik
Prüf- und Zertifizierungsstelle
im BG-PRÜFZERT

Hauptverband der gewerblichen
Berufsgenossenschaften

Translation

EC-Type Test Certificate

05160

no. of certificate

Name and address of the
holder of the certificate:
(customer) FRABA-VITECTOR GmbH
Schanzenstraße 35
51063 Köln

Name and address of the
manufacturer: see customer

Ref. of customer:

Ref. of Testing and Certification Body:
23.520.28/02-16-263 Sto/Ow

Date of Issue:
28.06.2005

Product designation: Opto-electronic pressure sensitive edges

Type: OSE-3020; OSE-3021;
OSE-3022; OSE-3025

Intended purpose: In the temperature area of +5°C to +55°C.

Testing based on: 73/23/EEC "Low voltage directive"
89/336/EEC "EMC-directive"
DIN EN 1760-2 "Safety of machinery – Pressure sensitive protective devices
- Part 2: General principles for the design and testing of
pressure sensitive edges and pressure sensitive bars" (2001-07)

Remarks: The pressure sensitive edges fulfil the requirements of category 3 according to DIN EN 954-1 (1997-03).
The requirements according to section 4.23 to EN 1760-2 for OSE-3020 (21)(22) are in a sense fulfilled,
because the exceed of the limit will be balanced by the reduce of the follow-up distance.

The type tested complies with the provisions laid down in the directive 98/37/EC (**Machinery**).

The present certificate will become invalid at the latest on:

31.12.2009

Further provisions concerning the validity, the extension of the validity and other conditions are laid down in the Rules of
Procedure for Testing and Certification of April 2004.

Stommel

.....
Dipl.-Ing. Stefan Stommel
Manager of the certification body

PZB02E
05.04



Postal address:
Postfach 51 05 80
50941 Köln

Office:
Gustav-Heinemann-Ufer 130
50968 Köln

Phone: 0221 / 3778 - 6301
Fax: 0221 / 3778 - 6322

In any case, the German original shall prevail.

OSE - CERTIFICATES

European notified body
Identification number 0340



Fachausschuss Elektrotechnik
Prüf- und Zertifizierungsstelle
im BG-PRÜFZERT

Hauptverband der gewerblichen
Berufsgenossenschaften

Translation

EC-Type Test Certificate

05162

no. of certificate

Name and address of the holder of the certificate:
(customer) FRABA-VITECTOR GmbH
Schanzenstraße 35
51063 Köln

Name and address of the manufacturer:
see customer

Ref. of customer:

Ref. of Testing and Certification Body:
23.520.28/02-16-263 Sto/Ow

Date of Issue:
28.06.2005

Product designation: Opto-electronic pressure sensitive edges

Type: OSE-4000; OSE-4001;
OSE-4002; OSE-4005

Intended purpose: In the temperature area of +5°C to +55°C.

Testing based on: 73/23/EEC "Low voltage directive"
89/336/EEC "EMC-directive"
DIN EN 1760-2 "Safety of machinery – Pressure sensitive protective devices
- Part 2: General principles for the design and testing of
pressure sensitive edges and pressure sensitive bars" (2001-07)

Remarks: The pressure sensitive edges fulfil the requirements of category 4 according to DIN EN 954-1 (1997-03).
The requirements according to section 4.23 to EN 1760-2 for OSE-3020 (21)(22) are in a sense fulfilled,
because the exceed of the limit will be balanced by the reduce of the follow-up distance.
Replacement to EC-Type-test-certificate ET 01108.

The type tested complies with the provisions laid down in the directive 98/37/EC (**Machinery**).

The present certificate will become invalid at the latest on:

31.12.2009

Further provisions concerning the validity, the extension of the validity and other conditions are laid down in the Rules of Procedure for Testing and Certification of April 2004.

Stommel

Dipl.-Ing. Stefan Stommel
Manager of the certification body

PZB02E
05.04



Postal address:
Postfach 51 05 80
50941 Köln

Office:
Gustav-Heinemann-Ufer 130
50968 Köln

Phone: 0221 / 3778 - 6301
Fax: 0221 / 3778 - 6322

In any case, the German original shall prevail.

OSE – SENSORS



OSE-Sensor

T = Transmitter

R = Receiver

S = Set

Special lengths of cable are available upon request.

OSE - Sensors- Designation	Id No.	∅ Housing	Cable	Remark
OSE-S 1100	75130195	11 mm	10.5 m / 3.0 m	Transmitter / Receiver
OSE-S 1102	75130206	11 mm	6,5 m / 0,5 m	Transmitter / Receiver
OSE-S 1171	75130198	11 mm	10.5 m / 10.5 m	Transmitter / Receiver suitable for energy guiding chains

OSE – SENSORS

Technical data

General data	
Protection class	IP 68 (DIN VDE 0470)
Operation temperature	-20 °C - +75 °C
Range	0.4 m to max. 10 m
Material of the housing	Polyethylene
Diameter of the housing	11 mm
Length of the housing	37 mm for 11 mm diameter
Signaling cable	Polyurethane / Polyvinylchloride 3 x 0.14 mm ² , foil proof, notch-proof
Signaling cable (suitable for energy guiding chains)	Polyurethane / Polyester 3 x 0.15 mm ² , foil proof, uv-proof, notch-proof
Length of signaling cable	Maximum length from sensors to signal processing unit 200 m
Length of the power cable	From 3 m to 15 m (on request)
Sealing compound	Polyurethane
Color of the sealing compound	Transmitter: grey, Receiver: black

Drawings

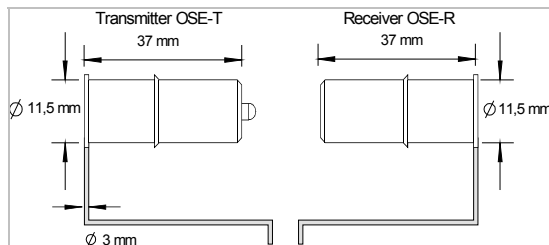

Connection diagram

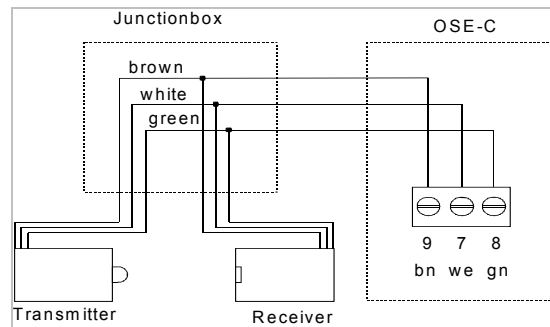

OPTOCHAIN – OVERVIEW SENSORS



OPC-Sensors

OSE-T = Transmitter Master-Edge

OPC-T = Transmitter Slave-Edge

OSE-R = Receiver, identical for Master- and Slave-Edge

Special lengths of cable are available upon request.

OSE - Sensors- Designation	Id No.	∅ Housing	Cable	Remark
OSE-S 1100	75130195	11 mm	10,5 m / 3,0 m	Master-Edge; Transmitter / Receiver
OPC-S 1100	10006777	11 mm	10,5 m / 3,0 m	Slave- Edge; Transmitter / Receiver

OPTOCHAIN

Product Description

The OPTOCHAIN is based on the well-known optical safety edge OPTOEDGE.

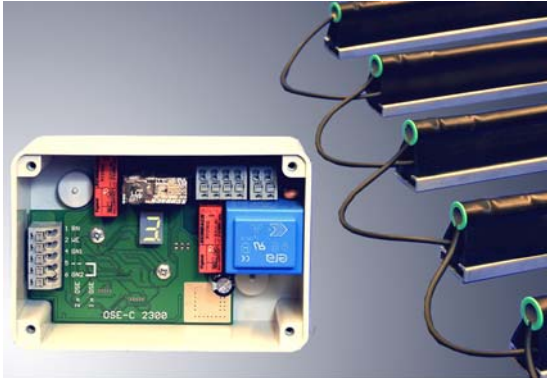

It has been developed to optimize the usage of several safety edges for the protection of one device. From now on it is possible to connect numerous safety edges serially to each other. The dynamic safety signal (OSE signal) is transferred from one safety edge to the next one. This signal can be interrupted at each separate safety edge. By this it is sufficient to connect only the signal of the last safety edge to the control unit. The OPTOCHAIN has been developed according to the safety category 3 described at EN ISO 13849-1:2006.

Functional Description

The OPTOCHAIN is a modular system of sensing edges for the use on automatic doors and machines. It is built up of one Master sensing edge and numerous Slave safety edges which are connected in series.

The Master is nothing else than the well-known OPTOEDGE. The Slaves are characterized by a special transmitter while the receivers are standard OSE-sensors. The Slave transmitter is able to process an incoming safety signal of a previous sensing edge.

The serial connection of multiple sensing edges reduces the wiring effort and minimizes the number of safety channels which have to be analyzed by a control unit.

The outgoing safety signal is compatible to all existent control units with integrated OSE-interface. Thus there is no need for external control units if there is more than one safety edge to be mounted.

Safety Requirements

Doors and gates must be built and operated in such a way that their use does not endanger people. This means that all hazardous points must be avoided or safeguarded if this is not possible.

The EN 12453 suggests protection devices which stop the door movement before the hazardous points are reached. These protection devices have to fulfil at least the requirements of safety category 3 according to EN 954-1 (EN 13849-1). The safety requirements for machine protection are determined through a hazard analysis and risk assessment. The OPTOCHAIN fulfils all requirements of safety category 3 according to EN 13849-1 and is thus usable as protection device for a wide variety of applications.



OPTOCHAIN

Application

The OPTOCHAIN can be used for a wide variety of applications. If there is more than one edge to be secured the OPTOCHAIN is a very good solution. Revolving doors, sliding gates or machinery protection are only a few of the possible applications.



Connection

A serial connection of safety edges is realized by a direct cable connection of consecutive safety edges. The first safety edge is the so called Master safety edge while all the others are Slave safety edges. Characteristically for the Master is a transmitter with a single cable outlet. The standard OSE transmitter or the new low power OSE transmitter can be used as Master transmitter.

There are two different versions of the OPTOCHAIN, which differentiate mainly by the number of cable outputs. The 2-cable version simplifies the connection of consecutive safety edges. By using different coat colors it will be easy to identify the different functions of the cables.

The 1-cable version should be preferred if all the cables are merged on a central place in the wiring.

The wiring diagrams of the two variants are shown in the following.

Master Transmitter OPC-MT

The Master transmitter determines the dynamic of the generated safety signal. A standard OSE-transmitter can be used as well as one of the new low power transmitters. It has to be connected to the according receiver OPC-MR. The system of transmitter and receiver represents a standalone sensing edge with safety category 4.

Slave Transmitter OPC-ST

The Slave transmitter is connected to the receiver of the previous sensing edge. The incoming safety signal is processed and leads to the activation of the transmitter. Activated the slave transmitter builds up a separate safety edge in combination with a receiver. By this the safety signal can be forwarded over several sensing edges.

The Slave Transmitter fulfils the requirements of safety category 3 (EN 13849-1).

Safety of OPTOCHAIN

The safety category of the OPTOCHAIN is determined by the slave sensing edges. Regarding the EN 13849-1 the OPTOCHAIN in combination with an appropriate control unit fulfils the requirements of safety category 3.

OPTOCHAIN

Connection of the OPTOCHAIN

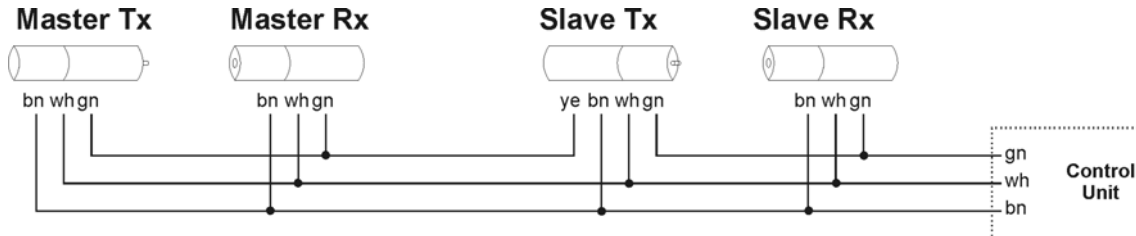

Cable Connection Master Transmitter OSE-T / OSE-R

Wire	Function
Green	OSE-Signal
Brown	+ 12 V
White	0 V

Cable Connection Slave Transmitter OPT-T

Wire	Function
Green	OSE-Signal of Slave Receiver
Yellow	OSE-Signal of Master Receiver
Brown	+12 V
White	0 V

Cable Connection Slave Receiver OSE-R

Wire	Function
Green	OSE-Signal
Brown	+12 V
White	0 V

OPTOCHAIN

Technical Data Master OSE-T / OSE-R

Protection Class	IP 68 (DIN VDE 0470)
Operation Temperature	-20°C to +75°C
Range	0,4 m to max. 10 m
Power Supply	12 V DC (+10% / -10%)
Current Consumption	Max 60 mA / Sensing Edge
Housing Material	Polyethylene
Housing Diameter	11 mm
Housing Length	37 mm
Cable	Polyurethane / Polyvinylchloride, 0,14 mm ² , foil proof, notch-proof
Cable Lengths	0.5 to 15 m (on Request)
Sealing Compound	Polyurethane
Color of Sealing Compound	Transmitter: grey Receiver: black

Technical Data Slave OPC-T / OSE-R

Protection Class	IP 68 (DIN VDE 0470)
Operation Temperature	-20°C to +75°C
Range	0,4 m to max. 10 m
Power Supply	5 V DC – 24 V DC (+10% / -10%)
Current Consumption	Max 60 mA / Sensing Edge
Housing Material	Polyethylene
Housing Diameter	11 mm
Housing Length	37 mm
Cable	Polyurethane / Polyvinylchloride, 0,14 mm ² , foil proof, notch-proof
Cable Lengths	0.5 to 15 m (on Request)
Sealing Compound	Polyurethane
Color of Sealing Compound	White

OPTOCORD



OPTOCORD-Modules

OPT-CF = fixed part of the OPTOCORD

OPT-CM = moved part of the OPTOCORD

OSE-LS = low.-power OSE-sensors, Set consisting of transmitter and receiver

Art. Name	Art. No.	Included Items	Description
OPT-S 3000	10007428	OPT-CM 3000, incl. 2 AA-Batteries; OPT-CF 3000, incl. 5 m Connection Cable	OPTOCORD Set, consisting of fixed and moved module
OPT-S 3001	10007356	OPT-CM 3000, incl. 2 AA-Batteries; OPT-CF 3001, incl. 5 m Connection Cable	OPTOCORD Set, consisting of fixed and moved module, Version for appli- cation with GFA Elektromaten Control Units
OSE-LS 1102	10004397	Cable Length: 0,5 m Receiver/ 6,5 m Transmitter	OSE-Set, low-power sensors for use with OPTOCORD
OPT-A 0001	10007357	Mounting-Kit for Bracket	Mounting Bracket for OPT-CF

VITECTOR

FRABA

OPTOCORD

Product description

The new wireless signal transmission unit OPTOCORD fulfils the requirements of safety category 3 in accordance with EN 13849-1 and is compatible to all OSE interfaces.

Specially designed low-power OSE sensors allow an extended battery lifetime and thus ensure a reliable operation of the system.



Requirements

Optical sensing edges have become a standard device to detect obstacles in the doorway during the closing cycle of an automated door. Previously a spiral cable was utilised to connect the sensing edge to the door control unit. In many cases the spiral cable had been in the way, tangling around salient parts of the door and eventually tearing, or just obstructing the light barrier.

The OPTOCORD system was designed to be used in such applications to replace the spiral cable.

Function

The communication takes part between a fixed-mounted and cable-bound part of the OPTOCORD (OPT-CF) and a battery-operated moving part (OPT-CM). The stationary part is connected with a cable to the door control unit while interacting by means of a bi-directional IR-signal transmission

with the moving part, to which the optical sensing edge is connected.

The OSE-signal transmission fulfils the requirements of safety category 3 in accordance with EN 13849-1.

Additionally a stop-signal, as used for e.g. a slack cable switch or a pedestrian door switch may be connected to the moving part as well. From the wall mount OPT-CF both signals are connected to the door control unit via cable.

In order to maximize the lifetime of the batteries a special generation of OSE sensors was developed, which uses only a fraction of the energy of normal optical sensing edges and operate on a very wide range of supply voltages between 4,5 and 24 V.

As part of the OPTOCORD system, the moving part is set into a sleep modus when the door is not in use and will only be activated shortly before the doors descent, which cuts the power supply even further.

Depending on the run time and operating frequency the battery lifetime will easily exceed 2 years.

Easy Installation

The broad sending and receiving angle of the two OPTOCORD units makes installation very easy.

A set of mounting brackets from galvanised steel is available.

The unit is recommended for door sizes below 7 meter.

VITECTOR

FRABA

OPTOCORD



Technical Data OPT-CF

Fixed part	OPT-CF	
Safety category	3 acc. to EN 13849-1	
Degree of protection	IP 54 acc. To DIN EN 60529	
Operating temperature	-20°C to +55°C	
Housing material	ABS (bottom), PC (lid)	
Dimensions (LxWxH)	111x37x34 mm	
Power supply	12 to 24 V DC - colour coded cable – do not switch polarity -	
Activation signal	System activated	+12 resp. 24 V DC on dedicated input (Activation)
	System in stand-by	0 V on activation input
Output signal	Sensing edge	Dynamic OSE-Signal
	Slack cable / door switch	Relays NCC

Cable assignment – OPT-CF 3000

Fixed part	OPT-CF
Brown	Power supply (12/24 V DC)
White	Ground (0 V)
Green	OSE-Signal
Grey	Activation signal (12/24 V DC)
Yellow, Rose	Stop-signal (e.g. slack cable / door switch), relays NC, do not connect when not in use

VITECTOR

FRABA

OPTOCORD

Cable assignment – OPT-CF 3001

For the application of the OPTOCORD with control units of GfA Elektromaten VITECTOR developed a special version of the stationary

part (OPT-CF). The moved part (OPT-CM) is identical to the standard version.

Cable Color	GfA connector	Description
Brown	X2, 2.1	Power Supply (12/24 V DC)
White	X2, 2.4	Ground (0 V)
Green	X2, 2.3	GfA Interface, activation and OSE-signal combined
Yellow	X2, 2.2	Safety Switch (e.g. Slack-Rope Switch)
Rose	X2, 2.1	

Dimensional Drawing

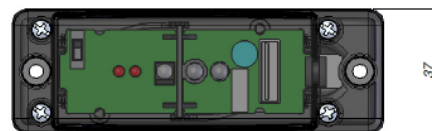
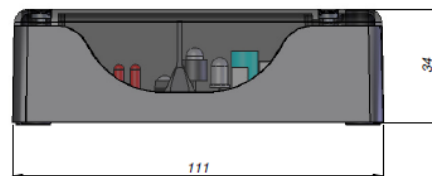
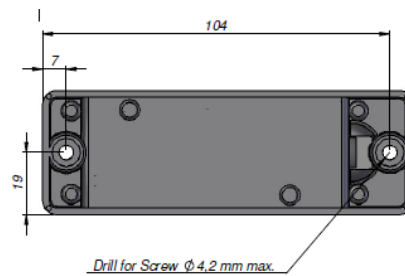
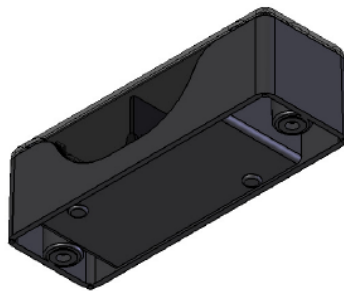
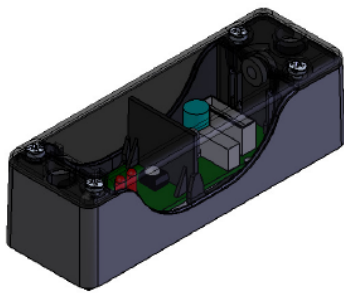

VITECTOR

FRABA







OPTOCORD

Status LED

To indicate the status of the OPTOCORD system two status LED are clearly visible on the

moving part .

The following table lists the different signals and conditions of the unit.

	Signal	Status
Red	OFF	System ready to operate
		Internal error - defect
		Interferencesn (OPT-CF & OPT-CM are not coded correctly)
Yellow		System in standby
		OSE sensing edge OK
		OSE sensing edge is activated
		No IR data transmission between units (only visible when system is activated)

VITECTOR

FRABA

OPTOCORD



Technical Data OPT-CM

OPT-CM	Moving Part
Safety category	3 acc. to EN 13849-1
Degree of protection	IP 54 acc. to DIN EN 60529
Operating temperature	-20°C to +55°C
Housing material	ABS (bottom), PC (lid)
Dimensions (LxWxH)	135x45x25 mm
Power Supply	2 x 1,5V AA Batteries
Battery lifetime	ca. 2 years, depending on activation time and frequency
Connections	1 x OSE-sensing edge 1 x Slack cable / door switch

Terminal assignment

Terminal	OPT-CM
1	OSE brown (+4,5V)
2	OSE white (GND)
3	OSE green (signal)
4*	Stop-signal (e.g. slack cable / door switch)
5*	

* = Place shunt to bridge when not in use

Activation- Time [s]	achievable Numbers of cycles	Battery lifetime in years with no. of daily operations		
		5 op./day	10 op./day	50 op./day
3	180.000	5,0	4,8	3,7
5	108.000	4,8	4,6	3,2
8	67.500	4,7	4,3	2,6
10	54.000	4,6	4,1	2,3
15	36.000	4,3	3,7	1,8
20	27.000	4,1	3,4	1,5
30	18.000	3,7	2,9	1,1

VITECTOR

FRABA

OPTOCORD

Dimensional Drawing

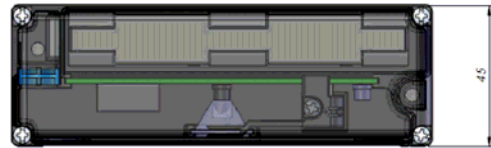
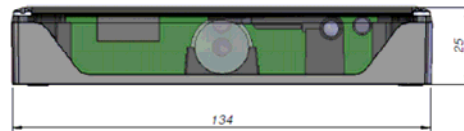
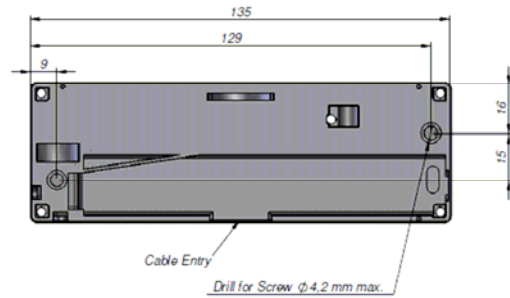
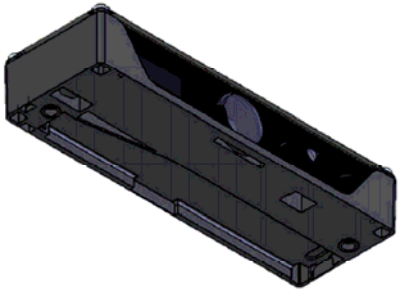
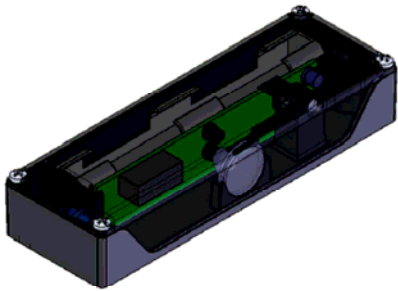

Technical Data OSE-LS

OSE-LS	Low-Power OSE sensors for use with OPTOCORD
Safety category	4 acc. to EN 954-1
Degree of protection	IP 68 (DIN VDE 0470)
Operating temperature	-20 °C to +75 °C
Power supply	5 – 24 V DC
Power consumption	max. 10 mA
Range of safety edge	0,4 m to 10 m

OPTOCORD

Installing the OPOTOCORD

Despite the broad angle of the signal transmission it has to be made sure, that the light beam remains unobstructed.



Coding

To prevent interferences between two OPTOCORD systems mounted on adjoining doors, it is possible to change the coding of the two units. This can be carried out easily by setting the little switch in the OPT CF and the OPT-CM into the other position.

Activation

To allow a safe closing of a power operated door it is necessary to activate the OPT unit prior to each descent.

When utilising the slack cable switch / pedestrian door switch contact as well, this activation has to be carried out before each operation of the door.

Please consider, that the battery lifetime is only half as long in this case. While in standby mode the OPT CF does not transmit any signal to the

door control unit. After receiving the wake-up signal from the door control unit please allow up to 300 ms until the IR communication is established and the safety edge started operating. After the door operation the activation signal may be reset, the OPT-CM will change into the standby mode after 2 seconds thereafter.

If no specific interface is integrated in the door control unit, it may be possible to utilise one of the following alternatives.

pro

- Programmable output relays
- Photocell-test signals
- Warning light relays
- etc.



OPTOCORD

Mounting Bracket - OPT-A 0001

For an optimal function of the OPTOCORD, it is necessary to align OPT-CF and OPT-CM to each other. A bi-part mounting bracket (OPT-A 0001) allows the adjustment of the fixed part of the OPTOCORD to optimise the reception.

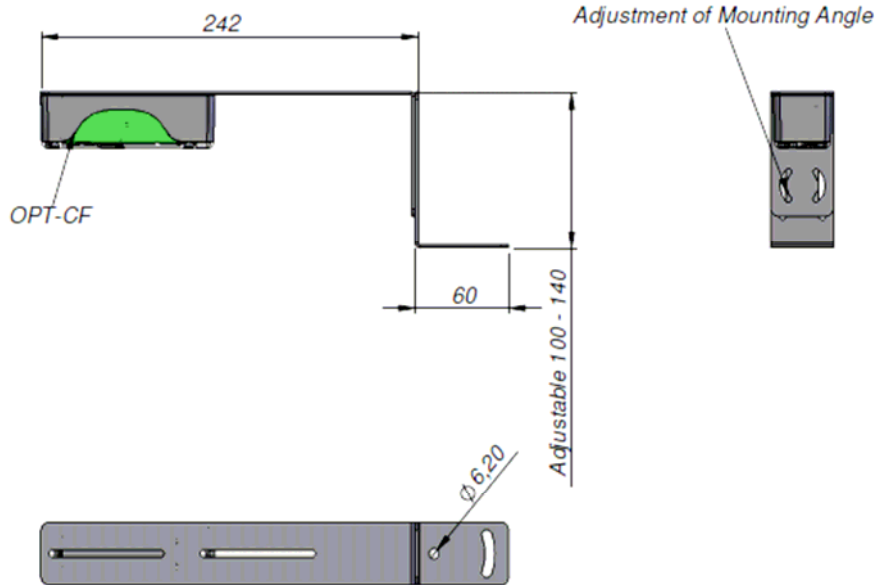
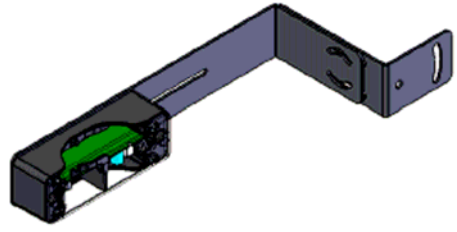

OSE – CONTROL UNITS



Control Units

C = Control Unit

Plug-in boards for various door control units are available upon request.

Control Units

Designation	Id-No.	Safety category	Supply voltage	Housing	
OSE- C 4524	75113003	1	24 V DC	Clip-on	Control unit for two safety edges
OSE- C 1001	75111007	1	24 V DC / AC	Surface type	Control unit for one safety edge
OSE-C 2300	75111023	3	230 V AC	Surface type	Control unit for two safety edges
OSE-C 2301	75111024	3	24 V DC	Surface type	
OSE- C 2323	75111016	3	230 V AC	Surface type	Control unit for two safety edges and additional NCC evaluation path
OSE- C 2324	75111017	3	24 V DC / AC	Surface type	
OSE-C 5024	75113010	3	24 V DC / AC	Clip-on	Control unit to a maximum of four safety edges
OSE- C 4024	75113000	4	24 V DC	Clip-on	

OSE – C 4524

Warning note:

Faultless and safe operating of the devices requires appropriate transportation, handling and storage. The signal transmission unit, the power supply and the enabling circuit have to be mounted and connected by a qualified electrician. The clamps should not be connected and released

under current-carrying conditions. The plug-in cards should not to be plugged in or to be unplugged under current-carrying conditions.

The customer's documentation and operating instructions must be read in its entirety before beginning an installation.

Technical data

General data	
Safety category	Cat. 1 according to DIN EN 954-1, certified (BG)
UL-Certification	E210129
Protection class	Housing IP 40, Contact No. IP 20 (DIN VDE 0470)
Housing material	Polyethylene (black), Crastin (grey)
Housing dimensions	Width: 22.5 mm, Height: 100 mm, Depth: 120 mm
Fitting positions	Any alignment
Operation temperature	+5 °C to +55 °C
Supply voltage	OSE-C 4524: 24 V DC +20 % / -10 %
Frequency range	48 Hz – 64 Hz
Power consumption	max. 4 VA
External fuse	0.2 A slow (not contained in appliance)
Transient voltage suppression	III/4 kV according to DIN VDE 01110, part 1
Soiling category	Cat. 2 according to DIN VDE 01110, part 1
Cyclic duration factor	100 % CDF
Weight	0.34 kg
Response time	16 ms

Indications and terminal assignments	
Voltage supply (Power)	LED green
OSE 1	LED green
OSE 2	LED green
Input contacts	
bn, wh, gn1, gn2	Transmitter / Receiver signal 1 bzw. 2 – wh/gn1 bzw. 2/bn
A1, A2	Voltage supply 24 V DC
Output contacts	
11, 12, 14	Output contacts OSE 1 / OSE 2 (safety contact)
21, 22, 24	Signaling contacts OSE 1 / OSE 2

Relay data	
Contact material	Hard silver, AgCdO
Operating voltage max.	250 V AC / 24 V DC
Operating current max.	6 A
Switching capacity	8 V 24 V DC, 250 VA, AC15: 230 V / 2 A, DC13: 24 V / 3 A
Soiling category	Soiling cat. 2 according to DIN 0160, part 1
Transient voltage suppression	III/4 kV according to DIN VDE 0160
Mechanical service life	2 x 10 ⁷ switching capacity

Connection diagram OSE-C 4524

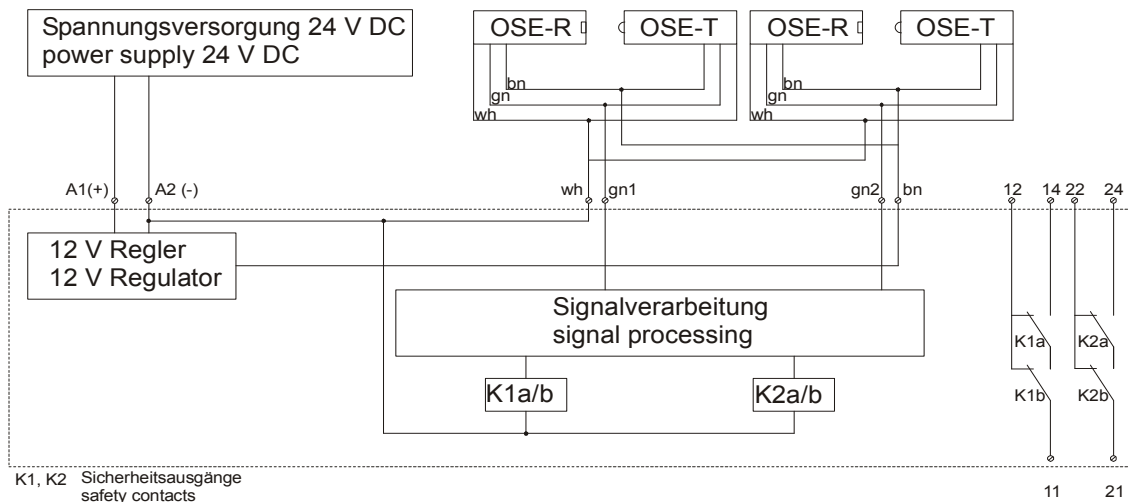

Output signals

The control units do not need an external reset signal. They behave in accordance with the requirements of DIN EN 1760-2, figure A3.

The output contacts 11, 12 and 14 monitor both safety edges. They change their condition, when one or both of the edges are actuated. The contacts 21, 22 and 24 are used for signaling the condition of the edges. If only one OSE is connected to the control unit, the terminals gn1 and gn2 have to be connected.

OSE

The brown and the white leads of the optoelectronic safety edges (OSE) are connected in parallel to the terminals marked bn (brown) and wh (white). The green leads of the edges are connected to terminal gn1, and terminal gn2 respectively.

OSE - C 4524

Drawing

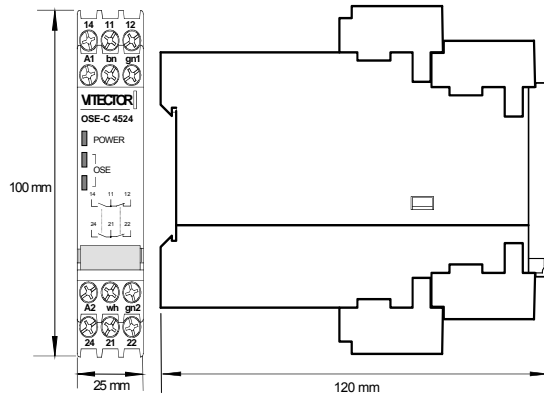

Notes for the mounting

When assembling the control unit into a service cabinet, sufficient distance to a source of heat (> 20 mm) must be observed.

Protection class IP 54 is require

Operating status, fault diagnosis, trouble-shooting OSE-C 4524

Indication	Operating status	Possible cause	Remedy
All LEDs on	OK		
Green LED (Power) out	Error	No voltage or wrong voltage; Control unit defective	Apply voltage; Check voltage
Green LEDs (OSE) out	Actuation or error	Light beam interrupted; Leads interrupted short circuit; Profile damaged Terminal assignment wrong; Only one edge connected Control unit defective	Check whether light path unobstructed; Check leads; Test OSE without profile; Check Terminal assignment Connect gn1 and gn2

OSE - C 1001



Scope

This manual is intended for the external control unit OSE-C 1001, in combination with the opto-edge sensors OSE-T and OSE-R.

Description

The external control unit OSE-C 1001 has been developed according to the requirements of safety-category 2 of EN 954-1. The device, consequently can be utilized for automated doors and gates in accordance with the European standards EN 12453 and EN 12978. Without using a testing signal the control unit complies with the safety

category 1 and can not be applied for human protection according to the EN 13241-1 and EN 12453.

The OSE-C 1001 works with a power supply of 24 V DC. It can be use with AC power supply also (ATTENTION: the maximum power supply is reduced.)

The control unit is designed for one OSE safety edge. When the safety edge detects an obstacle, the safety contact 3 and 4 opens. At the same time the second contact 1 and 2 close.

The contact 1 and 2 can be used to reverse the door. There is no time delay between opening contact 3 and 4 and closing contacts 1 and 2.

Mounting of the enclosure

The enclosure may be mounted with two bolts on any surface, even on surfaces with vibrations (Max. surface vibrations 10 to 55 Hz, 3.3-mm double amplitude, Shock resistance 100 m/s²).

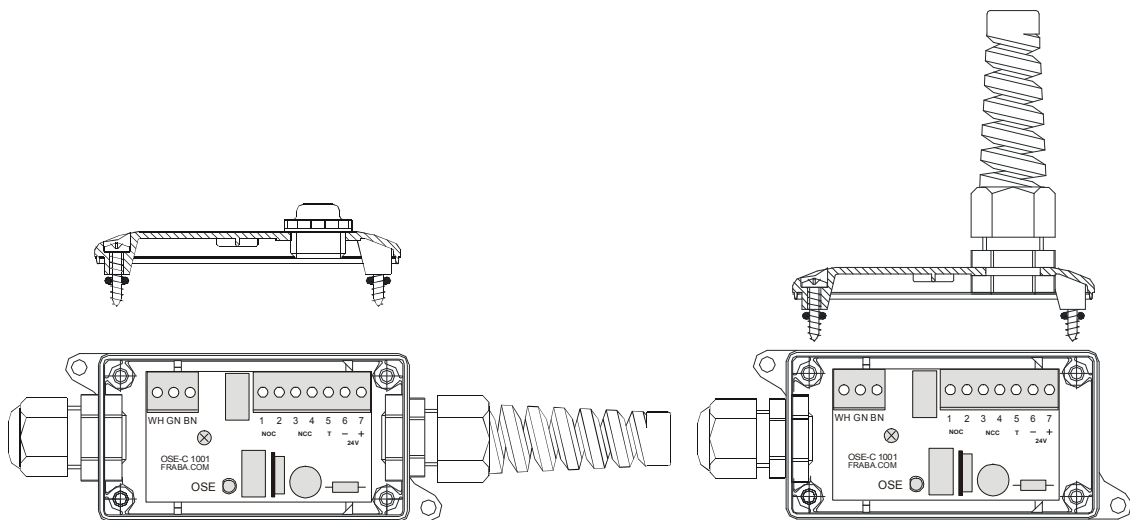

O S E - C 1 0 0 1

Technical data

General data	
Safety category	Cat. 2 according to DIN EN 954-1
Protection class	Housing IP 65 (DIN VDE 0470)
Housing material	ABS (light grey, similar RAL 7035)
Housing dimensions	Width: 48,5 mm, Height: 40 mm, Depth: 90 mm
Fitting positions	Any alignment
Operation temperature	-20 °C to +55 °C
Supply voltage	24 V DC +20 % / -10 % 24 V AC, +5/ -35 %
Frequency range	48 Hz – 64 Hz
Power consumption	max. 1,5 W
External fuse	not contained in appliance
Cyclic duration factor	100 % ED
Weight	0.34 kg
Response time	16 ms

Relay data	
Operating voltage max.	125 V AC / 60 V DC
Operating current	max. 0,5 A; min 10 mA
Switching capacity	62,5 VA / 30 W

Terminal description

Terminal designation	Function
Power 6, 7	Power supply: : 24 V DC +20 % / -10 %; 24 V AC, +5/ -35 %
1 BN	12 V – Power supply for OSE transmitter and receiver unit (brown lead)
2 WE	0 V – Supply for OSE transmitter and receiver unit (white lead)
4 GN	Signal transmission for connection of first safety edge optical (green lead)
1,2 NOC	contact closes if safety edge is actuated
3,4 NCC	Safety contact, contact opens if safety edge is actuated
5	Testing input, permanent + 24 V for testing 0 V

OSE - C 1001

Indication

LED	Status when lit
OSE	Safety contact closed

Operating status, fault diagnosis, trouble-shooting

Indication	Operating status	Possible cause	Remedy
LED "OSE" lit	no error		
LED "OSE" out	not ready	no power supply	proving power supply
		Testing input (5) is not connected	set jumper between 5 and 7
		safety edge defect	proving all wires; changing safety edge

Connection OSE safety edge

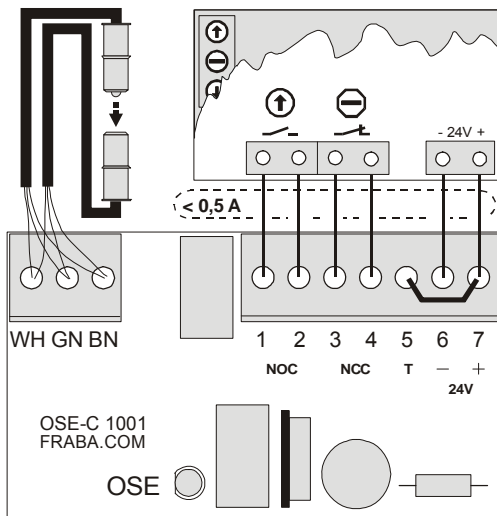

No testing, using contact 1, 2 to reverse the door

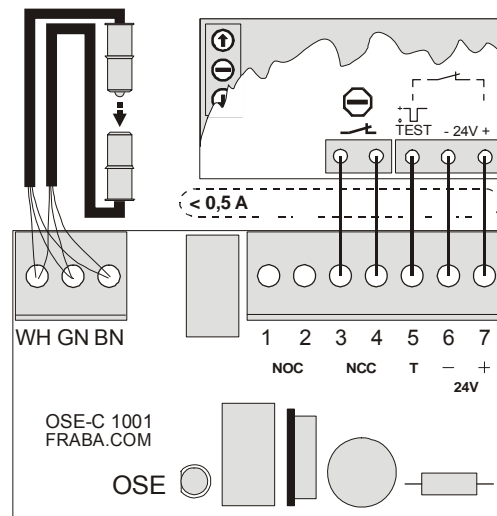

Using testing input reversion of door with door control unit.

OSE - C 2300 / OSE - C 2301



Scope

This manual is intended for the external control unit OSE-C 2300 (230V) or OSE-C 2301 (24V), in combination with the opto-edge sensors OSE-T and OSE-R.

Description

The external control unit, OSE-C 2300 / 2301 has been developed according to the requirements of safety-category 3 of EN 954-1. The device consequently can be utilized for automated doors and gates in accordance to the European standards EN 12453 and EN 12978.

The control unit will monitor up to two optical safety edges. The contacts of the redundant output-relay (terminals 33/34,) open, if one of the two installed optical safety edges is actuated. A differentiation between the two optical safety edges is not possible.

After the opening of the output-relays, a NO-reverse contact (terminals 23/24) will be closed

for a short period to re-open the door. The time delay before the door reverses is set to 50 ms. The relay is actuated for a duration of 500 ms.

For easy installation the unit is equipped with quick release terminals. The electric wires without conductor sleeves are to insert into the connection terminals from above with the following procedure: Open a clamp by pressing the lever with a small screwdriver. Insert the wire into the clamp. Release the lever. The wire now is fixed correctly. (Attention: Do not press the levers for opening too strong, because they could be damaged!)

Mounting of the enclosure

The enclosure may be mounted with two bolts on any even, non-vibrating surface. The two fixture holes are pre-punched and may be opened carefully on site. Drilling with a power drill is forbidden. When the housing is firmly mounted, the bolts have to be covered with the enclosed plastic caps.

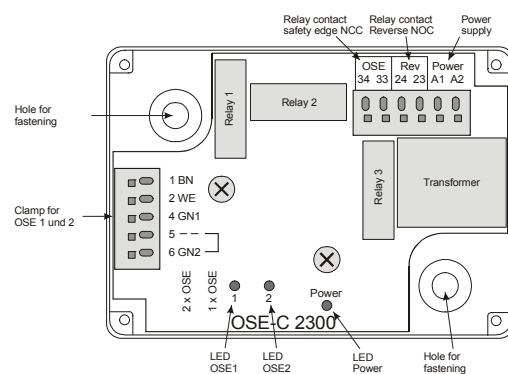

O S E – C 2 3 0 0 / O S E – C 2 3 0 1

Technical data

General data	
Safety category	Cat. 3 according to DIN EN 954-1
Protection class	IP 56 (DIN VDE 0470)
Housing material	PS, grey RAL 7035, grey cover
Housing dimensions	Length: 83 mm, Width: 123 mm, Height: 61 mm
Operation temperature	-20 °C to +55 °C
Fitting position	Any alignment
Supply voltage	OSE-C 2300 230 V AC \pm 20 % OSE-C 2301 24 V DC \pm 20
Frequency range	48 Hz - 64 Hz
Power consumption	2,8 VA
External fuse	not necessary
Transient voltage suppression	III/4 kV according to DIN VDE 01110, part 1
Soiling category	Cat. 2 according to DIN VDE 01110, part 1
Cyclic duration factor	100 % ED
Weight	0.36 kg

Indication and terminal assignments	
LED "Pow"	LED green – Readiness for working
LED "1"	Safety edge on clamp 4 is working
LED "2"	Safety edge on clamp 6 is working
Input contacts	
1, 2, 3, 4, 5, 6	Transmitter / Receiver signal 1, Transmitter / Receiver signal 2,
A1, A2	Supply voltage
Output contacts	
23, 24	Reverse contact
33, 34	Release contact OSE 1 / OSE 2 (safety contact)

OSE – C 2300 / OSE – C 2301

Terminal assignment

Terminal designation	Function
Power A1, A2	Power supply : OSE-C 2300: 230 V AC +/- 10%; protection class II (DIN EN 60529) OSE-C 2301: 24 V DC +/- 20 %
1 BN	12 V – Power supply for OSE transmitter and receiver unit (brown lead)
2 WE	0 V – Supply for OSE transmitter and receiver unit (white lead)
4 GN1	Signal transmission for connection of first safety edge optical (green lead)
5	In case of connection of one safety edge optical: wire bridge to terminal 6 In case of connection of two safety edges optical: without wire bridge
6 GN2	In case of connection of one safety edge optical: wire bridge to terminal 5 In case of connection of two safety edges optical: signal transmission of second safety edge optical (green lead)

Indications

LED	Status when lit
LED "Power"	Ready for working
LED "1"	Optical safety edge at terminal 4 in function and enabled
LED "2"	Optical safety edge at terminal 6 in function and enabled

When only one safety edge is in use, and terminals 5 and 6 are bridged, both LEDs have identical function.

Operating status, fault diagnosis, trouble-shooting

Indication	Operating status	Possible cause	Remedy
LED "Power" out of function	Not operative	Power supply defective or interrupted	Check power supply
LED "1" and/or "2" out of function	"OSE" – relays open	The respective safety edge optical open or defective	Discharge respective safety edge optical, otherwise check function
LED "1" and/or "2" blink periodical	Error-detecting mode in external control unit	Technical defect in external control unit	Switch on an off power supply. When identical error, change external control unit

Wiring diagram for one or two safety edges

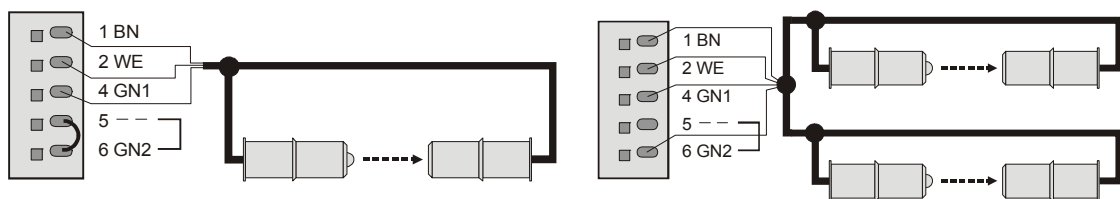

OSE – C 2323 / OSE – C 2324

Technical data

General data	
Safety category	Cat. 3 according to DIN EN 954-1
Protection Class	IP 65 (DIN VDE 0470)
Housing material	Polycarbonate, grey RAL 7035, transparent cover
Housing dimensions	Length: 94 mm, Width: 130 mm, Height: 60 mm (without PG-joints)
Operation temperature	-20 °C to +55 °C
Fitting position	Any alignment
Supply voltage	OSE-C 2323 230 V AC \pm 20 % OSE-C 2324 24 V DC \pm 20 % or 24 V AC \pm 20 %
Frequency range	48 Hz - 64 Hz
Power consumption	max. 7 VA
External fuse	0.2 A slow (not contained in appliance)
Transient voltage suppression	III/4 kV according to DIN VDE 01110, part 1
Soiling category	Cat. 2 according to DIN VDE 01110, part 1
Cyclic duration factor	100 % CDF
Weight	0.5 kg (OSE-C 2323) / 0.36 kg (OSE-C 2324)
Response time	max. 16 ms

Indication and terminal assignments	
LED "Pow"	LED green – Readiness for working
LED "Halt"	LED yellow – Slack rope/extra passage switch chain closed
LED "OSE 1"	LED green – Opto-electronic safety edge at clamp 4 in regular condition and enabled
LED "OSE 2"	LED green – Opto-electronic safety edge at clamp 6 in regular condition and enabled
Input contacts	
1, 2, 3, 4, 5, 6	Transmitter / Receiver signal 1, Transmitter / Receiver signal 2, Slack rope switch / extra passage switch chain
A1, A2	Supply voltage
Output contacts	
13, 14	Release contact, safety switch
23, 24	Reverse contact
33, 34	Release contact OSE 1 / OSE 2 (safety contact)

OSE - C 2323 / OSE - C 2324

Relay data	Output 33/34	Output 13/14, 23/24
Contact material	Hard silver, AgCdO	Hard silver, AgCdO
Operating voltage max.	250 V AC/DC	250 V AC / 24 V DC
Limit of constant current	4 V	6 V
Operating current max.	4 A	8 A 24 V DC, 250 VA, AC15: 230 V / 2 A, DC13: 24 V / 3 A
Switching capacity	1000 VA	8 A 24 V DC, 250 VA, AC15: 230 V / 2 A, DC13: 24 V / 3 A
Mechanical service life	30 x 10 ⁶ switching capacity	20 x 10 ⁶ switching capacity
Fuse	4 A slow (not contained in appliance)	6 A slow (not contained in appliance)
Protection class	Soiling category 2 according to DIN 0160, part 1 Transient voltage suppression III/4 kV according to DIN VDE 0160	

OSE

The brown and the white leads of OSE are connected in parallel to the terminals 1 - marked bn (brown) - and 2 - marked wh (white). The green leads of the edges are connected to terminal 4 = gn1, and terminal 6 = gn2 respectively. If only one edge is connected the terminals 5 and 6 have to be bridged.

Release contact (NCC)

The relay contact 33/34 is closed, when the safety edge is not actuated. In case of an error or an actuation, the contact opens. The release contact for the safety switches (13/14) behaves likewise.

Reverse contact

The signal created by the reverse contact is a delayed signal, which is generated 50 or 100 ms after the actuation (selectable by jumper setting) of the safety edge and lasts for 0.5 seconds.

The relay contact (23/24) is open, when the safety edge is not actuated. In case of an error or an actuation, the contact closes as described above. the release signal could be used to reverse the door and thus to release the obstacle.

Switches

Between contacts 1 and 3 safety switches can be connected (slack rope switches and extra passage switches. They got to be designed as release contacts (NCC). The condition of the switches is indicated at the contacts 13/14.

Drawing

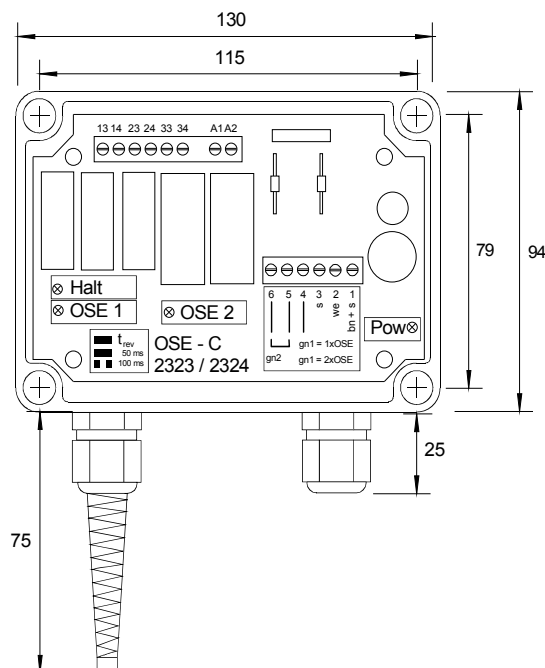

OSE - C 2323 / OSE - C 2324

Connection diagram OSE-C 2323 / OSE-C 2324

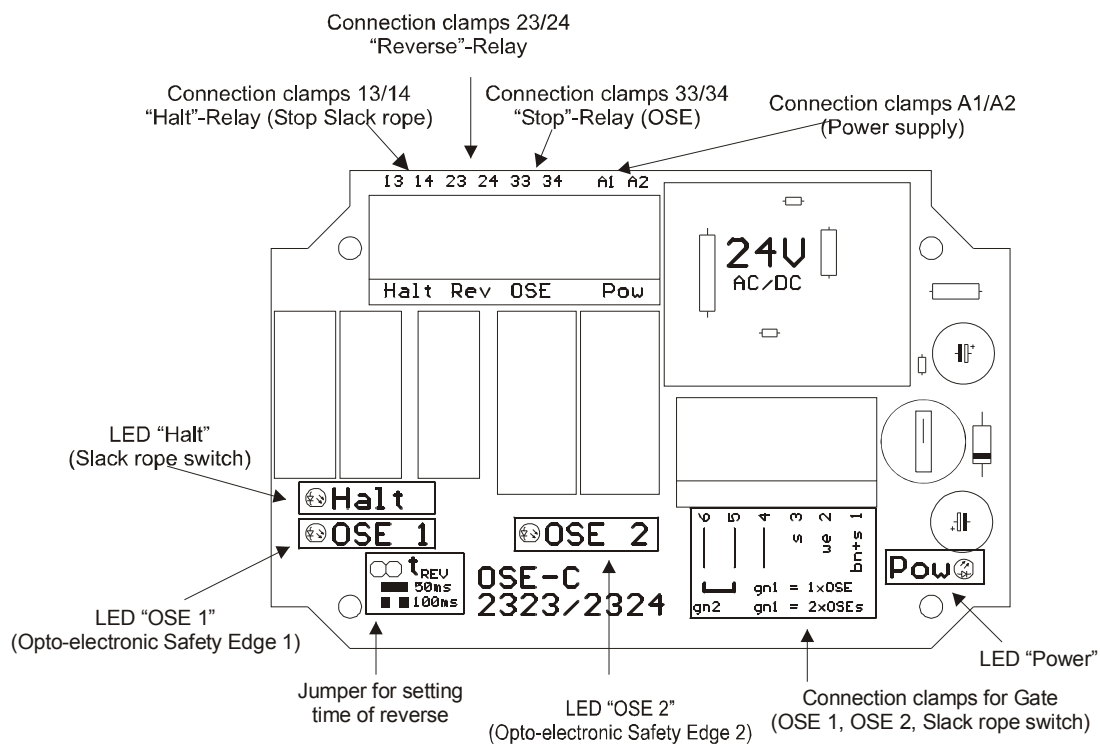

Operating status, fault diagnosis, trouble-shooting OSE-C 2323 / OSE-C 2324

Indication	Operating status	Possible cause	Remedy
All LEDs on	OK		
Green LED (Pow) out	Error	No voltage or wrong voltage; Control unit defective	Apply voltage; Check voltage
Green LED (OSE 1, OSE 2) out	Actuation or error	Light beam interrupted; Leads interrupted short circuit; Profile damaged Terminal assignment wrong; Control unit defective	Check whether light path unobstructed; Check leads; Test OSE without profile; Check terminal assignment
Green LED (Halt) out	Error	Safety switch open; Lead to the safety switches interrupted	Check the safety switches; Check leads

Technical data

General data	
Safety category	3 according to DIN EN 954-1, Certified (BG)
Protection class	Housing IP 40, Terminal block IP 20 (DIN VDE 0470)
Housing material	Polyethylene (black), Crastin (grey)
Housing dimensions	Width: 22.5 mm, Height: 100 mm, Depth: 120 mm
Fitting position	Any alignment
Operation temperature	-10 °C to +55 °C
Supply voltage	24 V DC (+20% / -10%) / 24 V AC (+10 % / -10 %)
Power consumption	max. 4 VA
Fuse	1 A slow (not contained in appliance)
Transient voltage suppression	III/4 kV DIN, VDE 0110, part 1
Soiling condition	Cat. 2 according DIN VDE 0110, part 1
Cyclic duration factor	100 % CDF
Weight	0.15 kg
Response time	18 ms

Indications and terminal assignments	
Power	LED green – Readiness for working
Stop	LED green – Release
OSE1 – OSE4	LED green – safety edge 1 – 4 OK
Input contacts	
we, bn, gn1 – gn4	Signaling transmitter 1 – 4 OK
A1 / A2	Supply voltage
X2 / X3	Reset
Output contacts	
13/14	Safety contact S
X1	Signaling contact (semiconductor, PNP)

Relay data	
Contact material	Hard silver AgNi 10 + 0.2 µm Au
Operating voltage max.	250 V AC / 250 V DC
Marginal continuous current	2 A
Operating current max.	2 A
Switching capacity	AC15: 230 V / 3A; DC13: 24 V / 4 A
Fuse	2 A slow (not contained in appliance)
Mechanical service life	> 10 ⁷ switching capacity

Relay data	
Contact material	Hard silver, AgNi 10 + 0,2 µm Au
Operating voltage max.	250 V AC / 250 V DC
Marginal continuous current	2 A
Operating current max.	2 A
Switching capacity	AC15: 230 V / 3A; DC13: 24 V / 4 A
Fuse	2 A inert (do not contain in the equipment)
Mechanical service life	> 10 ⁷ Switching cycles

Notes for the mounting

When assembling the control unit into a service cabinet, sufficient distance to a source of heat (> 20 mm) has to be observed therefore a service cabinet of protection class IP 54 is necessary.

OSE

The brown and the white leads of the optoelectronic safety edges are connected in parallel to the terminals marked bn (brown) and wh (white). The green leads of the edges are connected to terminal gn1, respectively to terminals gn1 – gn4.

Number	gn1	gn2	gn3	gn4
1	OSE1			
2	OSE 1		OSE 2	
3	OSE 1	OSE 2	OSE 3	
4	OSE 1	OSE 2	OSE 3	OSE 4

Release contact (NCC)

The relay contact between clamps 13 and 14 is closed in normal status of the safety edge. It opens at activations or faults and interrupts thereby. Releasing the circuit.

Signaling contact

A semiconductor output (signaling output, not safety directed) serves for signaling the fault to the control system (PNP-'Open-Collector').

Reset

- Manual Reset (X2 / X3)
- The manual reset meets the requirements of EN 1760-2 (Status diagram A2) and of section 5.4 DIN EN 954-1.
- Bridged Reset (X2 / bn)
- At bridged reset the system meets the requirements of EN 1760-2 (Status diagram A3).

Drawing

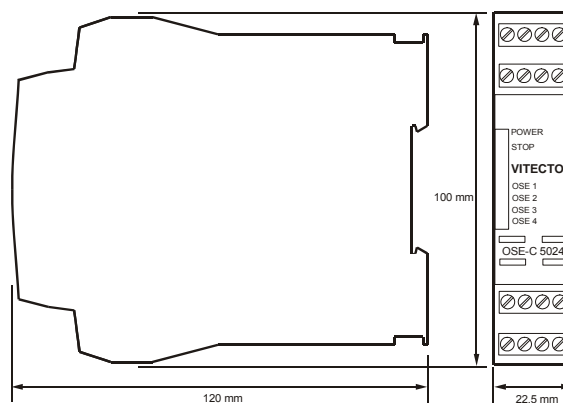

OSE - C 5024

Connection diagram OSE-C 5024

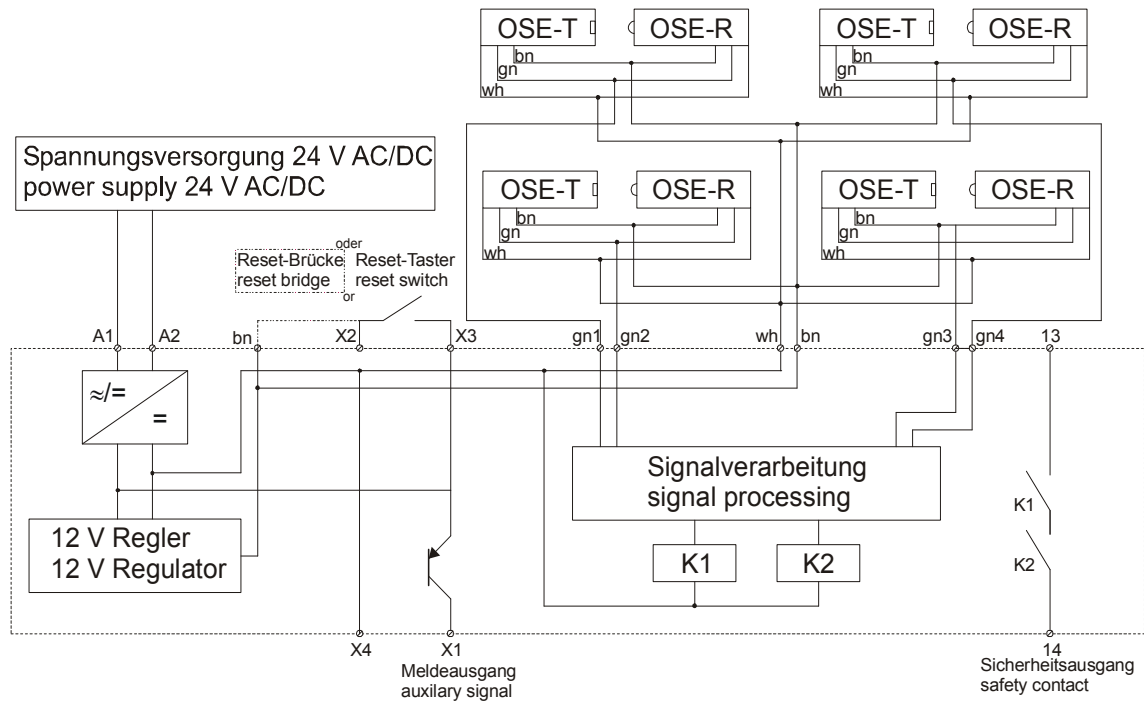

Operating status, fault diagnosis, trouble shooting OSE-C 5024

Indication	Operating status	Possible cause	Remedy
LED "Power" out	Not operative	Supply voltage interrupted or defective	Check voltage supply
LED "Stop" out	"Stop" – Relay open	At least one safety edge is activated or defective	Release safety edges; if necessary check functions
LED "OSE n" out	"Stop" – Relay open	The respective safety edge respective is activated or defective	Relieve safety edge; if necessary check functions
LEDs "OSE n" blink (running light)	Error detecting in device	Technical fault in control unit	Switch Supply voltage off and on. If the same fault happens change control unit

Technical data

General data	
Safety category	Cat. 4 according to DIN EN 954-1, Certified (BG)
UL-Certification	E210129
Protection Class	Housing IP 40, Terminal block IP 20 (DIN VDE 0470)
Housing material	Polyethylene (black), Crastin (grey)
Housing dimensions	Width: 22.5 mm, Height: 100 mm, Depth: 120 mm
Fitting positions	Any alignment
Operation temperature	+5 °C to +55 °C
Supply voltage	24 V DC (+20% / -10%)
Power consumption	max. 4 VA
Fuse	1 A slow
Transient voltage suppression	III/4 kV (DIN, VDE 0110, part 1)
Soiling-condition	Cat. 2 according to DIN VDE 0110, part 1
Cyclic duration factor	100 % CDF
Weight	0.2 kg
Response time	32 ms

Indications and terminal assignments	
Power	LED green
Channel / OSE	LED green
Input contacts	
we, bn, gn	Signaling transmitter
A1	Supply voltage (24 V DC)
A2	GND
X2 / X3	Reset
Output contacts	
13/14/23/24	Release, safety contact S
X1	Signaling-contact (Semiconductor NPN)

Relay Data	
Contact material	Hard silver, AgCdO
Operating voltage max.	250 V AC/DC
Continuous current max.	4 A
Operating current max.	4 A
Fuse	4 A slow (not contained in appliance)
Switching capacity	1000 VA
Mechanical service life	30 x 10 ⁶ contacts

Notes for the mounting

When assembling the control unit into a service cabinet, sufficient distance to a source of heat (> 20 mm) has to be observed, therefore a service cabinet of protection class IP 54 is necessary.

OSE

The leads of the opto-electronic safety edge (OSE) must be connected to the terminals marked bn (brown) wh (white) and gn (green).

Release contact (NCC)

The redundant relay contact is closed in the normal status of the safety edge. It opens at activation of faults and interrupts thereby releasing the circuit.

Signaling contact

A semiconductor output (signaling output, not safety directed) serves for signaling the faults to the control system (NPN-‘Open-Collector’).

Drawing

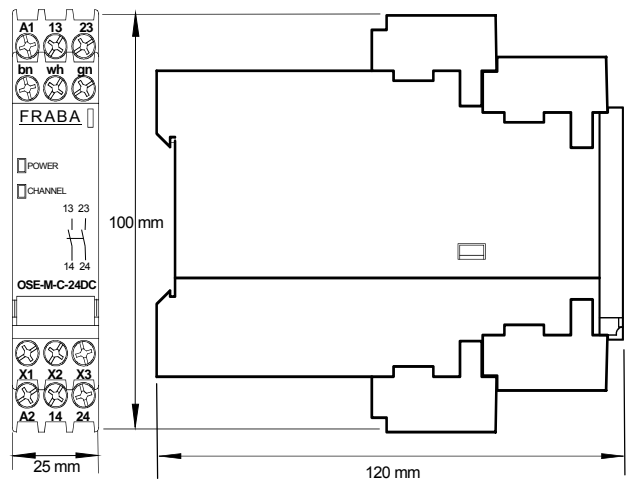

OSE - C 4024

Connection diagram OSE-C 4024

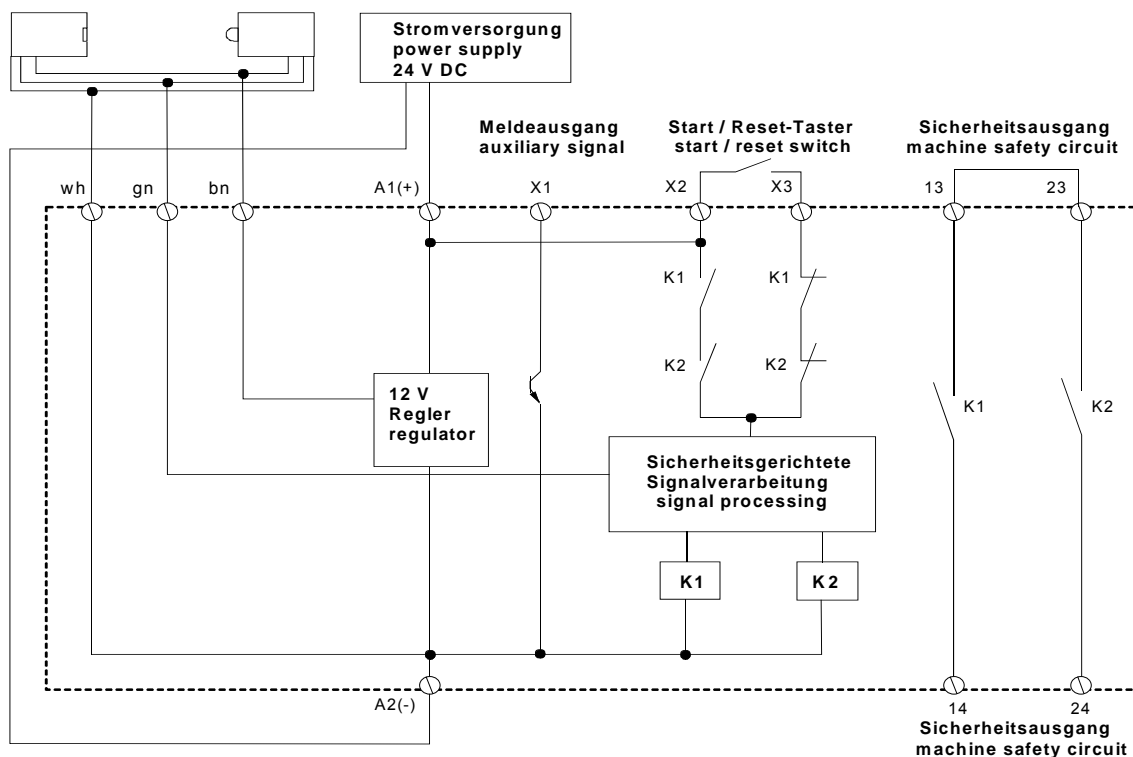

Operating status, fault diagnosis, trouble-shooting OSE-C 4024

Indication	Operating status	Possible cause	Remedy
LED "Power" out	OK		
Green LED (Power) out	Error	No voltage or wrong voltage; Control unit defective	Apply voltage; Check voltage
Green LED (OSE1 or OSE2) out	Actuation or error	Light beam interrupted; Leads interrupted short circuit; Profile damaged Terminal assignment wrong; Control unit defective	Check whether light path unobstructed; Check leads; Test OSE without profile; Check terminal assignment

OSE – OVERVIEW PROFILES



Overview profiles

The profiles must be stored and shipped without kinks and sharp bends. A pollution of the hollow chamber during the storage should be prevented by a suitable package. A longer storage (> 6 months) in rolls should be avoided.

Designation	Id-No.	Material	Dimension in mm (Width / Height)	Weight	∅ Sensor
OSE-P 25 30 00	75142050	EPDM	25 / 30	0.3 kg/m	11 mm
OSE-P 25 33 00	75142061	EPDM	25 / 33	0.3 kg/m	11 mm
OSE-P 25 33 00 NBR	10002453	NBR	25 / 33	0.3 kg/m	11 mm
OSE-P 30 58 00	75142062	EPDM	30 / 58	0.6 kg/m	11 mm
OSE-P 30 90 01	75142080	EPDM	30 / 90	0.9 kg/m	11 mm
OSE-P 20 40 01	75142044	EPDM	20 / 40 incl. sealing lip	0.3 kg/m	11 mm
OSE-P 25 90 00	75142016	EPDM	25 / 85 incl. Sealing lip	0.8 kg/m	11 mm
OSE-P 14 36 00	75142046	EPDM	14 / 36 incl. sealing lip	0.2 kg/m	11 mm
OSE-P 14 36 04	10006741	EPDM	14 / 36 incl. sealing lip	0.18 kg/m	11 mm
OSE-P 15 40 00	75142042	EPDM	15 / 40 incl. sealing lip	0.3 kg/m	11 mm
OSE-P 20 40 00	75142060	EPDM	20/40	0,3 kg/m	11 mm
OSE-P 25 75 01	75142010	EPDM	25 / 75 incl. sealing lip	0.6 kg/m	11 mm
OSE-P 25 75 00	75142030	EPDM	25 / 75 incl. sealing lip	0.7 kg/m	22 mm
OSE-P 45 60 00	75142085	EPDM	45/60 incl. sealing lip	0,9 kg/m	11 mm
OSE-P 45 60 01	75142041	EPDM	45/60 incl. sealing lip	1,1 kg/m	11 mm
OSE-P 45 60 02	75142086	EPDM	45/60 incl. sealing lip	0,62 kg/m	11 mm
OSE-P 45 60 04	10004735	EPDM	45/60 incl. Sealing lip	0,65 kg/m	11 mm

OSE – OVERVIEW PROFILES

General data of the signaling element	
Protection Class	IP 67
Length of wire of signaling transmitter	min. 0.4 m max. 10.0 m
Length of signaling line	max. 200 m
Tolerable weight	max. 500 N on any point of the effective sensing surface Exception: OSE-P 30 90 01 max. 400 N
Operating speed	min. 10 mm/s max. see details
Fitting position	Any alignment
Mounting	In distances of approx. 0.7 m with head or countersunk head screws (Ø: 3 mm – 6 mm)

Technical data (characteristic features of material)

General data	
International marking	EPDM (APTK)
Chemical marking	Ethylene-Propylene-Terpolymer
Rebound elasticity at 20 °C	Good (> 25 %)
Resistance against permanent deformation	Good
Elongation at tear	> 400 %
General weatherproofness	Excellent
Ozone resistance	Excellent (degree 0)
Oil resistance	Poor
Fuel resistance	Poor
Chemical solvent-resistance	Poor
General resistance against acids	Good
Salt water resistance	Stable
Light-resistance	Good
Temperature-resistance	
Short term approx.	-50 °C to +120 °C
Long-term approx..	-40 °C to +100 °C
Grocery-quality available	Possible with restrictions

O S E – O V E R V I E W P R O F I L E S

Limit deviations according to DIN ISO 3302-1

The measures of profiles in the drawings are featured according to tolerances of DIN ISO 3302-1.

This has to be taken into consideration in case of implant in a specific customer's profile.

Nominal sizes (in mm)		
More than	Up to	Tolerance according to class E2 (in mm)
0	1.5	± 0.25
1.5	2.5	± 0.35
2.5	4.0	± 0.40
4.0	6.3	± 0.50
6.3	10	± 0.70
10	16	± 0.80
16	25	± 1.00
25	40	± 1.30
40	63	± 1.60
63	100	± 2.00

OSE – DATASHEETS PROFILES

OSE-P 25 30 00

Specific data	
Hardness	70 ± 5 Shore A
Height	30 mm
Width	25 mm
Length of roll	50 m
Alu-Profile	ALU – 2509
Bumper	OSE-B 3518
Detection of fingers	Yes
Article No..	75142050
Weight	0,3 Kg/m
Dead surface region	70 mm
Operating speed	max. 100 mm/s
Op. temperature	5 °C to 55 °C
Protection Class	IP67

Drawing OSE-P 25 30 00

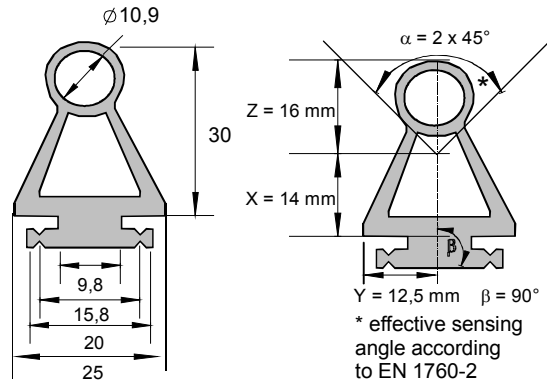

Parameters of measuring, temperature: T = 23 °C, fitting position: B (according to EN 1760-2), measuring point: C3 (according to EN 1760-2), operation speed: 100 mm/s to A 10 mm/s from A. The end sections are unable to detect fingers and must be marked accordingly.

Force travel relation diagram

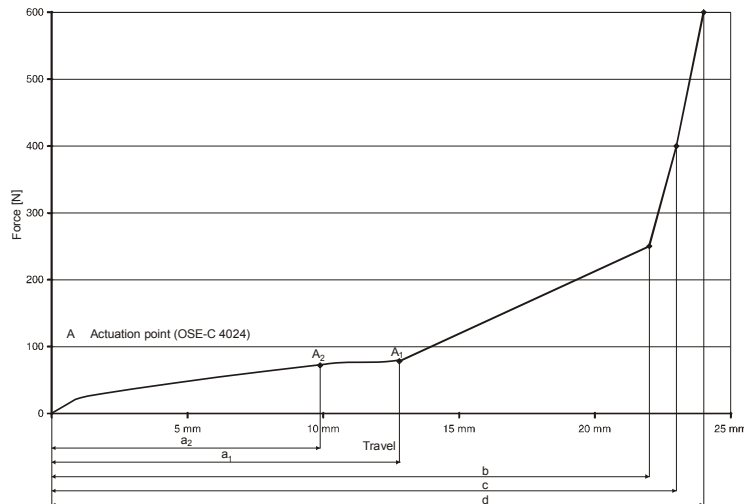

	OSE-C 4024		OSE-C 4524	
	Travel	Force	Travel	Force
a _{1/2} Pretravel	12,8 mm	80 N	9,8 mm	78 N
b Total travel to reach the force 250 N	22,0 mm	250 N	22,0 mm	250 N
c Total travel to reach the force 400 N	23,0 mm	400 N	23,0 mm	400 N
d Total travel to reach the force 600 N	24,0 mm	600 N	24,0 mm	600 N

Follow-up range = b/c/d – a_{1/2} (The follow-up time depends on machine's further processing and braking speed).

OSE – OVERVIEW PROFILES

OSE-P 25 33 00

Specific data	
Material	EPDM or NBR
Hardness	70±5 Shore A
Height	30 mm
Width	25 mm
Length of the roll	50 m
Alu-C Profile	ALU –2509
Bumper	OSE-B3518
Detection of fingers	Possible
Article.-No.	EPDM: 75142050 NBR: 10002453
Weight	0,3kg/m
Dead surface region	70 mm
Operating speed	max. 100 mm/s
Op. temperature	5 °C – 55 °C
Protection Class	IP67

Drawing OSE-P 25 33 00

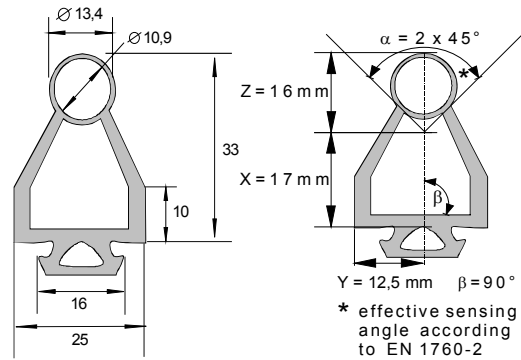

Measuring parameters, temperature: $T = 23\text{ °C}$, fitting position: B (according to EN 1760-2), measuring point: C3 (according to EN 1760-2), operating speed: 100 mm/s to A, 10 mm/s from A.

Force-travel-relation diagram

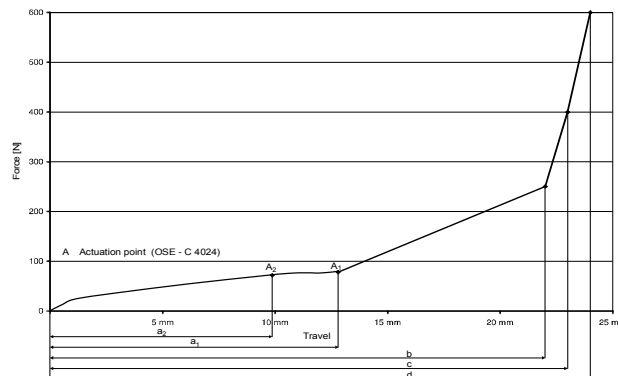

	OSE-C 4024		OSE-C 4524	
	Travel	Force	Travel	Force
a _{1/2} Pretravel	12.8 mm	80 N	9.8 mm	78 N
b Total travel to reach the force 250 N	22.0 mm	250 N	22.0 mm	250 N
c Total travel to reach the force 400 N	23.0 mm	400 N	23.0 mm	400 N
d Total travel to reach the force 600 N	24.0 mm	600 N	24.0 mm	600 N

OSE – OVERVIEW PROFILES

Follow-up range= $b/c/d - a/2$ (The follow-up time depends on machine's further processing and braking speed).

OSE – OVERVIEW PROFILES

OSE-P 30 58 00

Specific data	
Hardness	65±5 Shore A
Height	58,5 mm
Width	30 mm
Length of the roll	25 m
Alu-C Profile	ALU - 3009
Detection of fingers	Possible
Dead surface region	60 mm
Operating speed	max. 100 mm/s
Op. temperature	5 °C - 55 °C
Protection Class	IP67
Bumper	OSE-B 3518
Cover plate	OSE-A-30 58 00

Drawing OSE-P 30 58 00

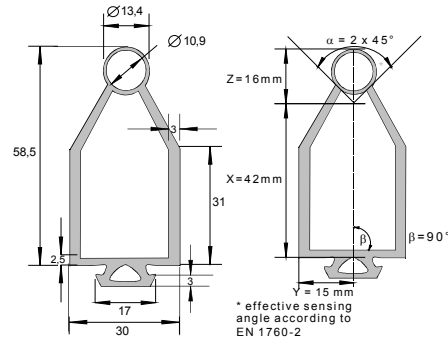

Parameters of measuring, temperature: T = 23°C,
 fitting position: B (according to EN 1760-2), measuring point: C3 (according to EN 1760-2), operating speed: 100 mm/s to A, 10 mm/s up from A.
 The end sections are unable to detect fingers and must be marked accordingly.

Force-travel-relation diagram

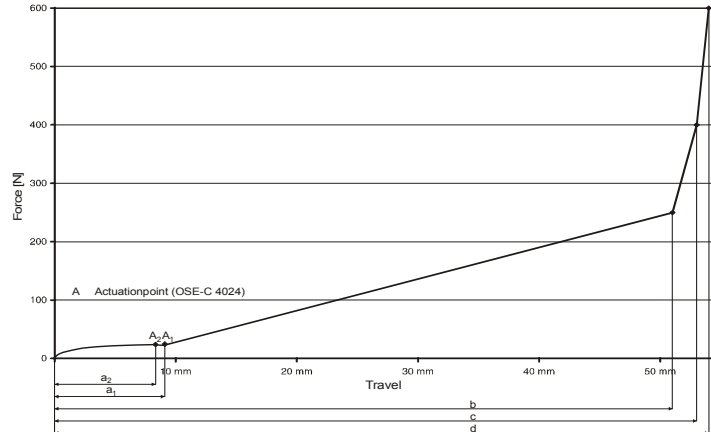

	OSE-C 4024		OSE-C 4524	
	Verformungsweg	Kraft	Verformungsweg	Kraft
a _{1/2} Ansprechweg	9,1 mm	23 N	8,0 mm	22 N
b Gesamtverformungsweg bis 250 N	51,0 mm	250 N	51,0 mm	250 N
c Gesamtverformungsweg bis 400 N	53,0 mm	400 N	53,0 mm	400 N
d Gesamtverformungsweg bis 600 N	54,0 mm	600 N	54,0 mm	600 N

Follow-up range= b/c/d – a_{1/2} (The follow-up time depends on machine's further processing and braking speed).

OSE – OVERVIEW PROFILES

OSE-P 30 90 01

Specific data	
Hardness	65±5 Shore A
Height	90 mm
Width	30 mm
Length of the roll	20 m
Alu-C Profile	ALU – 3009
Bumper	---
Detection of fingers	Yes
Article.-No.	75142080
Weight	0,9 kg/m
Dead surface region	50 mm
Operating speed	Max. 100mm/sec
Op. temperature	5 °C – 55°C

The end sections are unable to detected fingers and must be marked accordingly.

Drawing OSE-P 30 90 01

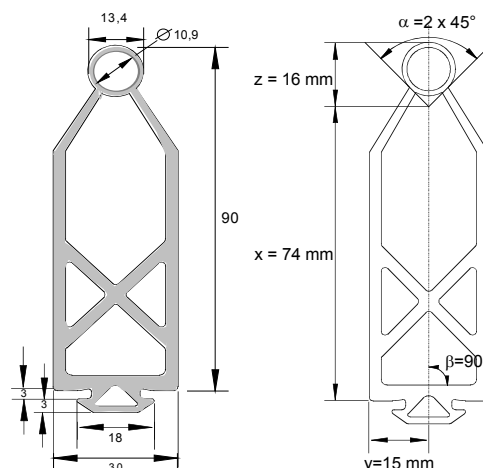

Parameters of measuring, temperature:

T=23°C, fitting position: B (according to EN 1760-2), measuring point: C3 (according to EN 1760-2), operating speed: 100 mm/s to A, 10 mm/s up from A.

Force-travel-relation diagram

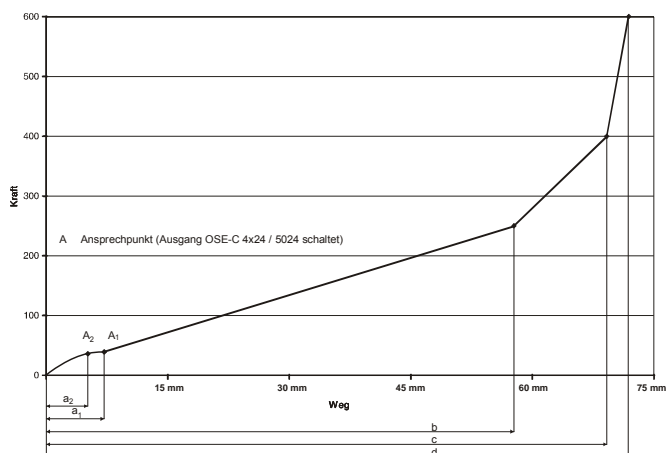

	OSE-C 4024		OSE-C 4524 / OSE-C 5024	
	Travel	Force	Travel	Force
a _{1/2} Pretravel	8,76 mm	40,5 N	7,16 mm	36,5 N
b Total travel to reach the force 250 N	58,4 mm	250 N	58,4 mm	250 N
c Total travel to reach the force 400 N	70,4 mm	400 N	70,4 mm	400 N
d Total travel to reach the force 600 N	72,8 mm	600 N	72,8 mm	600 N

Follow-up range= b/c/d – a_{1/2} (The follow-up time depends on machine's further processing and braking speed).

OSE - OVERVIEW PROFILES

OSE-P 20 40 01

Specific data	
Hardness	70±5 Shore A
Height	30 mm
Width	20 mm
Length of roll	50 m
Alu-Profile	ALU - 2007
Detection of fingers	No
Bumper	OSE-B 3518
Article No.	75142044
Operation speed	max. 50 mm/s
Weight	0,3 kg/m
Op .temperature	5 °C bis 55 °C
Protection class	IP67

Drawing OSE-P 20 40 01

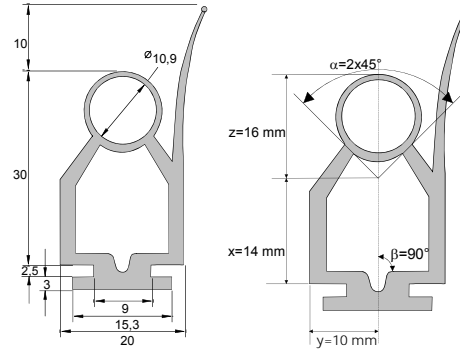

Parameters of measuring, temperatures:

T=23°C, fitting position: B (to EN 1760-2), measuring point: C3 (to EN 1760-2), operation speed: 50 mm/s to A 10 mm/s by A. reminder deformation after long term stress within 30s after discharge with smaller /same 20%

Force-travel-relation diagramm

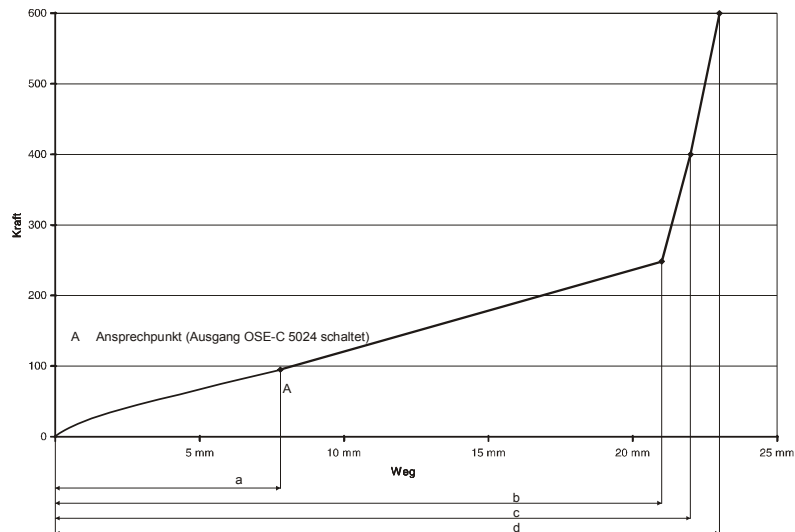

	OSE-C 5024	
	Travel	Force
a Pretravel	7,8 mm	94,5 N
b Total travel to reach the force 250 N	21,3 mm	250 N
c Total travel to reach the force 400 N	22,3 mm	400 N
d Tote travel to reach the force 600 N	23,2 mm	600 N

Follow-up range= b/c/d – a (The follow-up time depends on machine's further processing and breaking speed)

OSE - OVERVIEW PROFILES

.OSE-P 25 90 00

Specific data	
Harness	65±5 Shore A
Height	65 mm
Wight	25 mm
Length of roll	30 m
Alu-Profile	ALU - 2509
Detection of fingers	No
Bumper	OSE-B 5518
Article No.	75142016
Weight	0,8 kg/m
Op. temperature	-10 °C - 55 °C

Drawing OSE-P 25 90 00

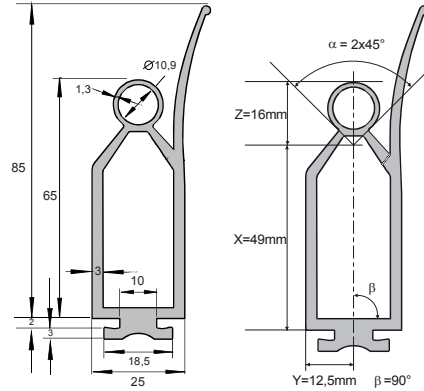

Parameters of measuring, temperatures: T = 23°C, fitting position: B (to EN 1760-2), measuring point: C3 (to EN 1760-2), operation speed: 100 mm/s to A 10 mm/s by A. reminder deformation mm/s to A 10 mm/s by A. reminder deformation after long term stress within 30s after discharge with smaller /same 20%

Force-travel-relation diagram

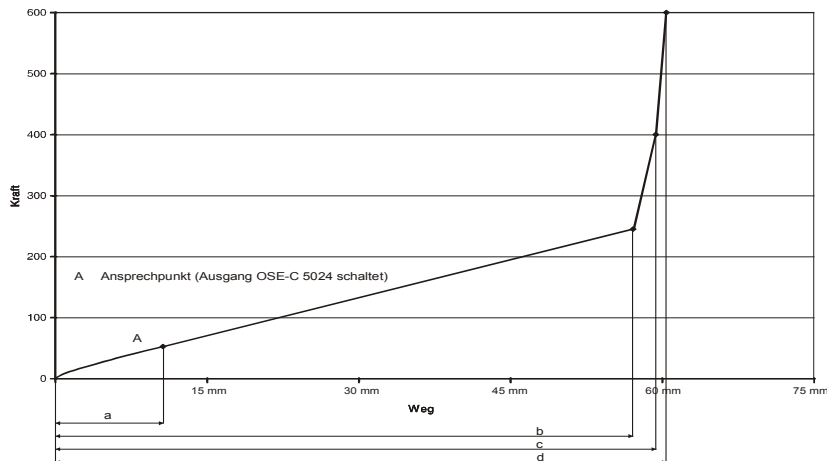

	OSE-C 5024	
	Travel	Force
a Pretravel	10,0 mm	53,0 N
b Total travel to reach the force 250 N	57,2 mm	250 N
c Total travel to reach the force 400 N	59,4 mm	400 N
d Total travel to reach the force 600 N	60,8 mm	600 N

Follow-up range= b/c/d – a (The follow-up time depends on machine's further processing and breaking speed.

OSE - OVERVIEW PROFILES

OSE-P 14 36 00

Specific data	
Hardness	70±5 Shore A
Height	28 mm
Width	14 mm
Length of roll	50 m
Alu-C Profile	---
Bumper	OSE-B 3512
Article .-No.	75142046
Weight	0,2 kg/m

Drawing OSE-P 14 36 00

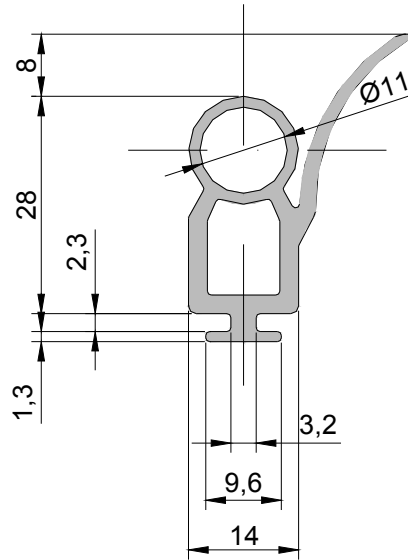

OSE-P 14 36 04

Specific data	
Hardness	70±5 Shore A
Height	28 mm
Width	14 mm
Length of roll	50 m
Alu-C Profile	---
Bumper	OSE-B 3512
Article .-No.	10002753
Weight	0,2 kg/m

Drawing OSE-P 14 36 04

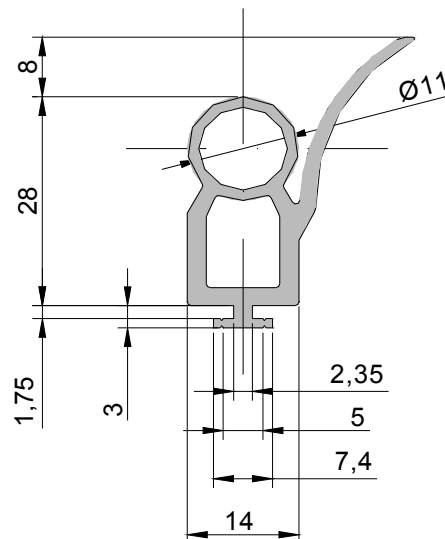

OSE - OVERVIEW PROFILES

OSE-P 15 40 00

Specific data	
Hardness	70±5 Shore A
Height	30 mm
Width	14.5 mm
Length of roll	50 m
Alu Profile	---
Bumper	OSE-B 3512
Article-No	75142042
Weight	0,3 kg/m

Drawing OSE-P 15 40 00

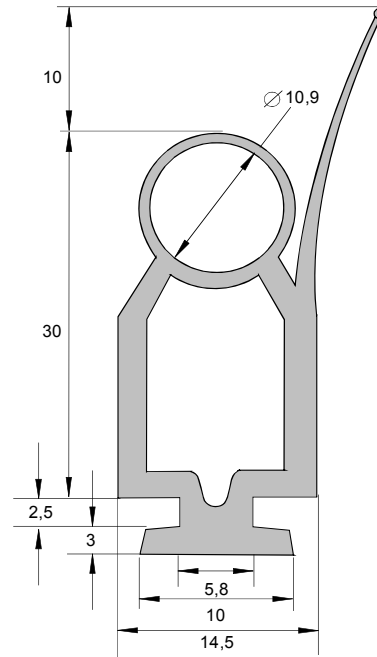

OSE-P 20 40 00

Specific data	
Harness	70±5 Shore A
Height	40 mm
Wight	20 mm
Length of roll	30 m
Alu-Profile	ALU – 2007
Bumper	OSE-B 3518
Detection of fingers	not tested
Article No.	75142060
Weight	0,3 kg/m
Dead surface region	not tested
Operating speed	max. 100 mm/s

Drawing OSE-P 20 40 00

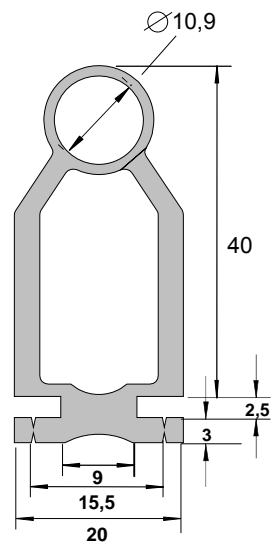

OSE – OVERVIEW PROFILES

OSE-P 25 75 01

Specific data	
Harness	70±5 Shore A
Height	55 mm
Wight	25 mm
Length of roll	22 m
Alu-Profile	ALU - 2509
Bumper	OSE-B 5518
Articel No.	75142010
Weight	0,6 kg/m

Drawing OSE-P 25 75 01

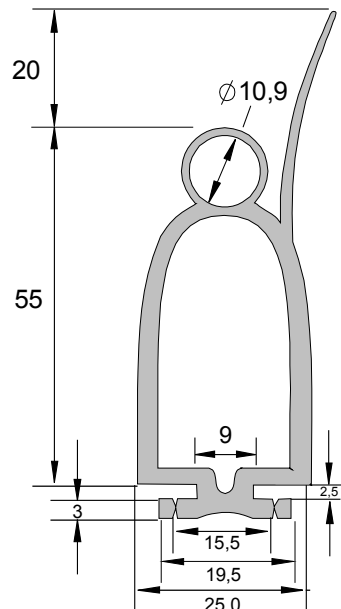

OSE-P 25 75 00

Specific Data	
Hardness	65±5 Shore A
Height	54 mm
Width	25 mm
Length of roll	30 m
Alu-C Profile	ALU – 2509
Bumper	OSE-B 5518
Article. No.	75142030
Weight	0,7 kg/m

Drawing OSE-P 25 75 00

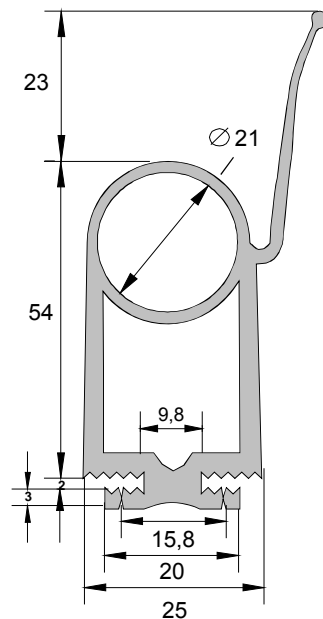

OSE – OVERVIEW PROFILES

OSE-P 45 60 00

Specific data	
Hardness	70±5 Shore A
Height	50 mm
Width	43 mm
Length of the roll	25 m
Alu-C Profile	ALU - 2509
Bumper	OSE-B 5328
Article No.	75142085
Weight	0,9 kg/m

Drawing OSE-P 45 60 00

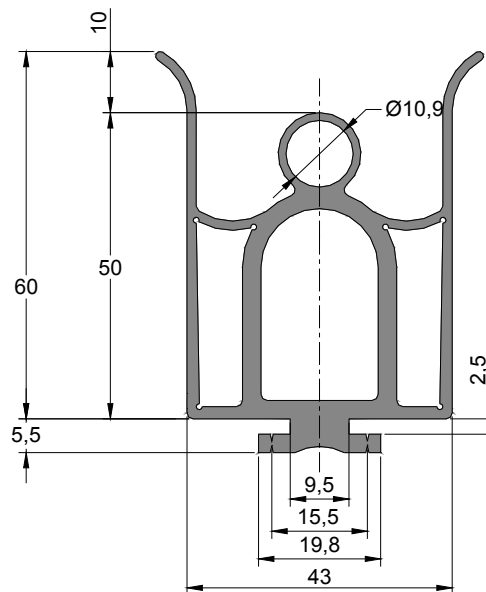

OSE-P 45 60 01

Specific data	
Hardness	65±5 Shore A
Height	50 mm
Width	44 mm
Length of the roll	25 m
Alu-C Profile	-
Bumper	OSE-B 5328*
Article No.	75142041
Weight	1,1 kg/m

*= on-site adjustment required

Drawing OSE-P 45 60 01

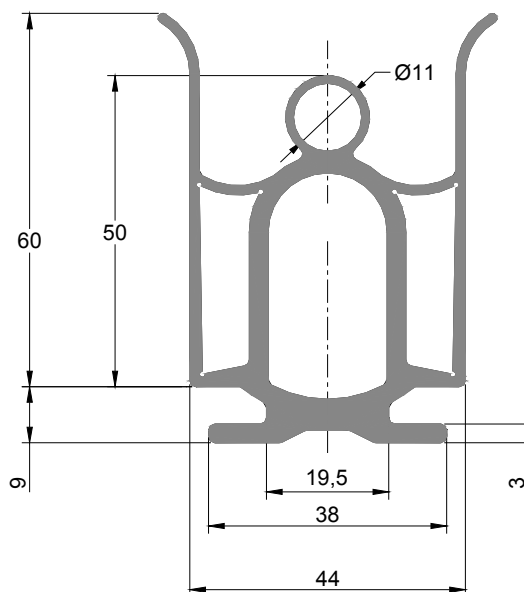

OSE – OVERVIEW PROFILES

OSE-P 45 60 02

Specific data	
Hardness	70±5 Shore A
Height	49,6 mm
Width	43 mm
Length of the roll	25 m
Alu-Profile	On side
Bumper	OSE-B 5328*
Articel No.	75142086
Weight	0,62 kg/m

*= Bumper may need modifications to fit in rail

Drawing OSE-P 45 60 02

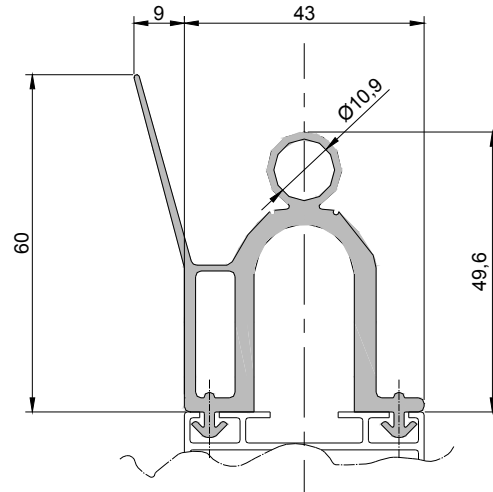

OSE-P 45 60 04

Specific data	
Hardness	70±5 Shore A
Height	49,6 mm
Width	43 mm
Length of the roll	25 m
Alu-Profile	On side
Bumper	OSE-B 5328*
Articel No.	10004735
Weight	0,65 kg/m

*= Bumper may need modifications to fit in rail

Drawing OSE-P 45 60 04

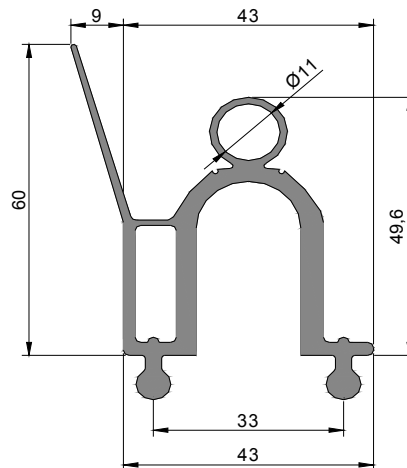

O S E – O V E R V I E W A C C E S S O R I E S

Overview accessories

Designation	ID-No.	Device	Remark
ALU - 2509	79221000	ALU - Mounting device	
ALU - 3009	79221012	ALU - Mounting device	
ALU - 2007	79221003	ALU - Mounting device	
AC 1000	75097330	Coil cord 3 leads	
AC 1001	75097340	Coil cord 4 leads	
AC 1002	75097350	Coil cord 5 leads	
AC 1004	75097361	Coil cord 6 leads	
AC 1106	75150023	Junction box	
AC 1107	75150025	Junction box with Coil cord	
AC 1300		Junction Box, large	
OSE-B 2516	75160030	Bumper	
OSE-B 2518	75160130	Bumper	
OSE-B 3512 Set	10003406	Bumper (2 Pizes)	
OSE-B 3514	75160040	Bumper	
OSE-B 3516	75160020	Bumper	
OSE-B 3518	75160120	Bumper	
OSE-B 5516	75160010	Bumper	
OSE-B 5518	75160110	Bumper	
OSE-B 2528	75160140	Modular bumper	
OSE-B 3228	75160150	Modular bumper	
OSE-B 3928	75160160	Modular bumper	
OSE-B 4628	75160170	Modular bumper	
OSE-B 5328	75160180	Modular bumper	
OSE-B 6728	75160185	Modular bumper	
OSE-B 7428	75160190	Modular bumper	
OSE-B 8828	75160200	Modular bumper	
OSE-A 25 33 00	75142166	Cover plate	For OSE-P 25 33 00
OSE-A 25 33 00 oil resistant	10003095	Cover plate oil resistant	For OSE-P 25 33 00
OSE-A 30 58 00	75142113	Cover plate	For OSE-P 30 58 00
OSE-A 30 58 00 oil resistant	75142117	Cover plate oil resistant	For OSE-P 30 58 00
OSE-A 1010	10000872	OSE Diagnose Tool	

ALU

Technical data

General data	
Material	ALMgSi 0.5 F22

Dimensions	Thickness	Height	Width	Weight
ALU - 2509	1.5 mm	9 mm	25 mm	0.18 kg/m
ALU - 2007	1.5 mm	7 mm	20 mm	0.19 kg/m
ALU - 3009	2.0 mm	9 mm	30 mm	0.31 kg/m

Drawings

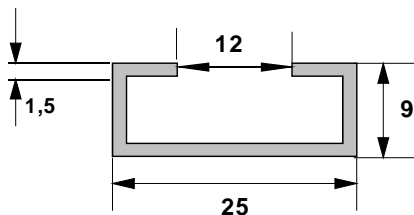
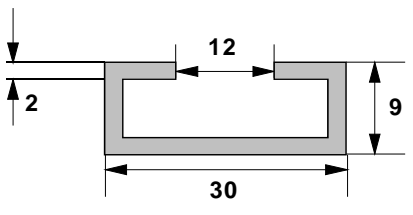
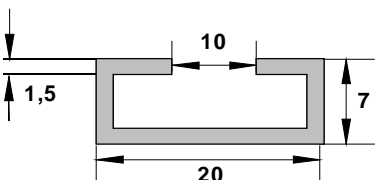
<p>ALU – 2509</p> 	<p>ALU – 3009</p> 
<p>ALU – 2007</p> 	

COIL CORDS

Coil cords

General technical data coil cords		
Material		PUR, black (Polyurethane)
Straight ends length		200 mm
Spiral length		750 mm
Maximal extension		4 x spiral length = 3 m
AC 1000	75097330	3 x 0,25 mm ² , outside diameter 5,5 mm (lead color green, white, brown)
AC 1001	75097340	4 x 0,25 mm ² , outside diameter 5,5 mm (lead color green, white, brown, yellow)
AC 1002	75097350	5 x 0,25 mm ² , outside diameter 7,5 mm (lead color green, white, brown, yellow, grey)
AC 1004	75097361	6 x 0.5 mm ² , outside diameter 7,5 mm (lead color brown, white, green, yellow, pink)

Coil cords



Junction Box AC 1107

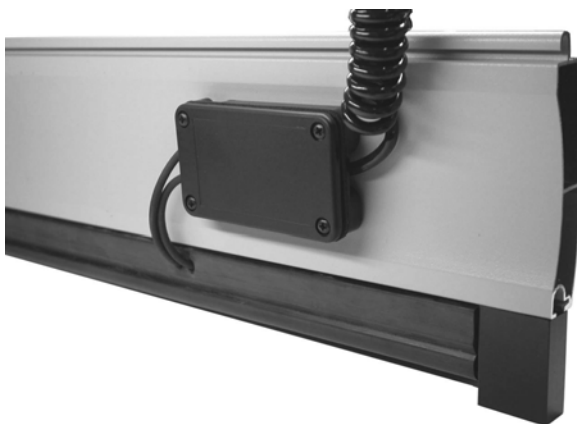

JUNCTION BOX

Junction box AC 1106

Technical data junction box AC 1106

Material	ABS, light grey (RAL 7035)		
Protection Class	IP 65 acc. to DIN VDE 0470		
Dimensions AC 1106 (without cable entries)	Length	Width	Height
	90 mm	48,5 mm	40 mm
Joints and their position	1 x M16 with bending protection and locknut		
	1 x M16 with 2-fold grommet and locknut		
	1 x M16 punch-out twisting sleeve		

Junction box AC 1106

The junction box AC 1106 is fitted with two open cable entries (M16) in the lid and in the box.

One M16 cable gland with bending protection sleeve, one M16 gland with a two fold grommet and a punch-out twisting sleeve are included.

Pre-punched cable entries in the walls of the box allow additional M16 or M20 cable entries.

A three pole terminal block for the OSE connection comes with the box.

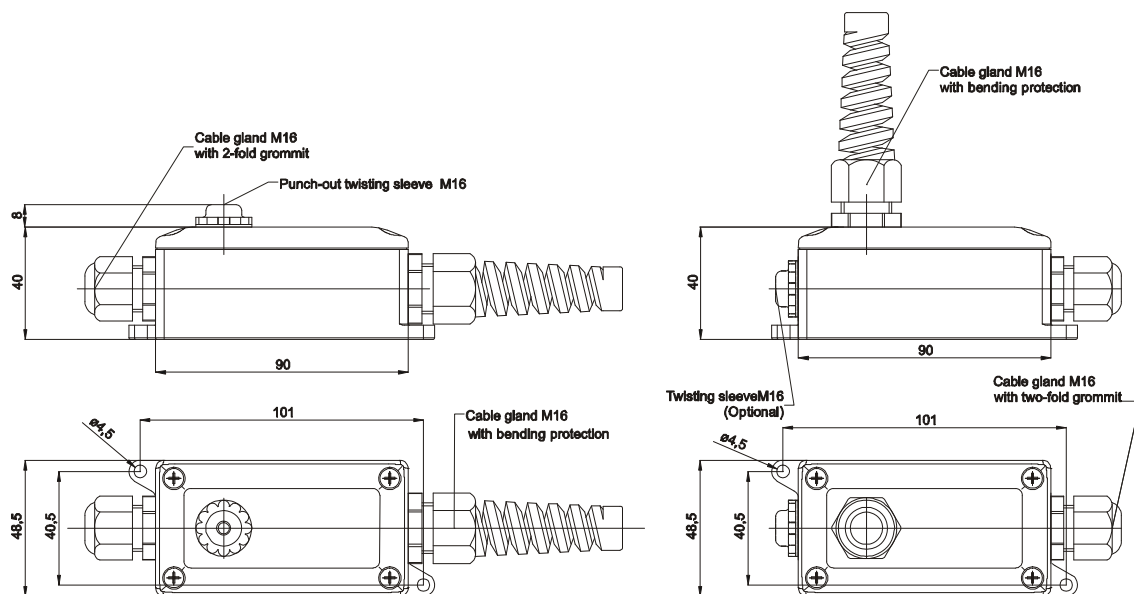

JUNCTION BOX

Junction Box AC 1300

Technical Data AC 1300			
Material	ABS, light grey, like RAL 7035		
Protection Class	IP 65 acc. to DIN VDE 0470		
Housing dimensions (without cable glands)	Length	Width	Height
	158 mm	60 mm	39 mm
Cable Glands	Up to 8 cable glands possible		

Junction Box AC 1300

The junction box AC 1300 is fitted with nine pre-punched cable entries.

One M16 cable gland with bending protection sleeve, one M16 gland with a two fold grommet and a connection terminal are included.

Pre-punched cable entries in the walls and the top of the box allow up to nine M16 cable entries.

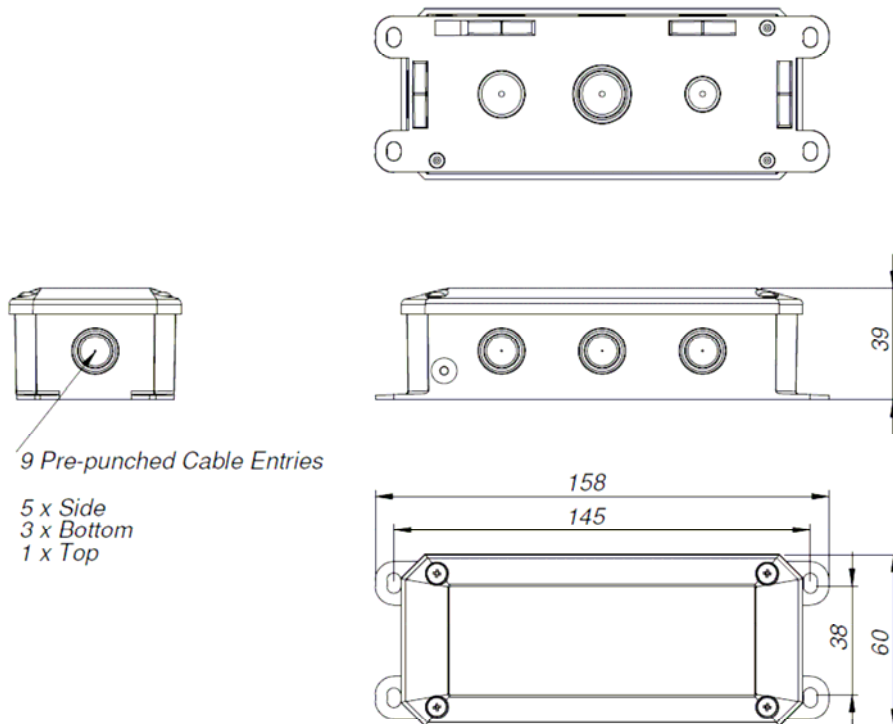

B U M P E R

Technical data

General data	
Material	Polypropylene

Designation	Width	Depth	Height	Screw	Type
OSE-B 2516	18	30	25	M6	one-piece
OSE-B 2518	18	30	25	M8	one-piece
OSE-B 3512 Set	12	24	35	M4	one-piece
OSE-B 3514	18	30	35	M4	one-piece
OSE-B 3516	18	30	35	M6	one-piece
OSE-B 3518	18	30	35	M8	one-piece
OSE-B 5516	18	30	55	M6	one-piece
OSE-B 5518	18	30	55	M8	one-piece
OSE-B 2528	25	45	25	M8	Modular
OSE-B 3228	25	45	32	M8	Modular
OSE-B 3928	25	45	39	M8	Modular
OSE-B 4628	25	45	46	M8	Modular
OSE-B 5328	25	45	53	M8	Modular
OSE-B 6728	25	45	67	M8	Modular
OSE-B 7428	25	45	74	M8	Modular
OSE-B 8828	25	45	88	M8	Modular

Drawings

bumper

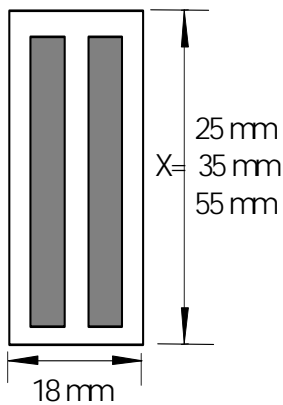

Modular bumper

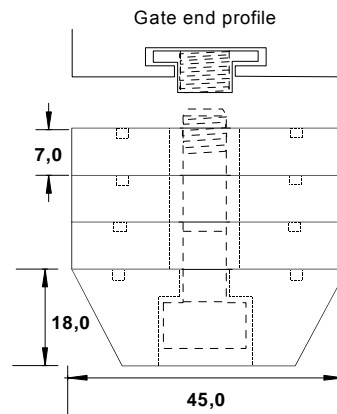

END COVERS

End covers

End covers serve as closings of opto electronic safety edges (OSE). The main application is sliding gates or machine construction.

The ability of the rubbers to bond to each other can be used for fastening but not for tightening the safety edge.

General data	
Material	Thermoplastic elastomere (TPE)
Mounting	Conglutinating

Designation	Width	Depth	Height	Profile
OSE-A 25 33 00	29 mm	19 mm	44 mm	OSE-P 25 33 00
OSE-A 25 33 00 Oil resistent	29 mm	19 mm	44 mm	OSE-P 25 33 00
OSE-A 30 58 00	34 mm	19 mm	70 mm	OSE-P 30 58 00
OSE-A 30 58 00 Oil resistent	34 mm	19 mm	70 mm	OSE-P 30 58 00

Drawings

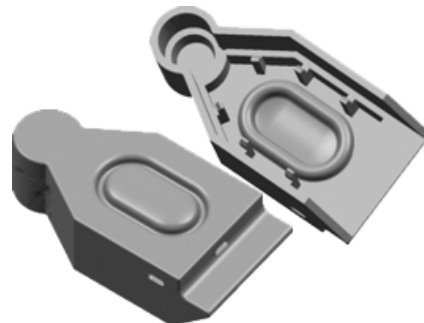
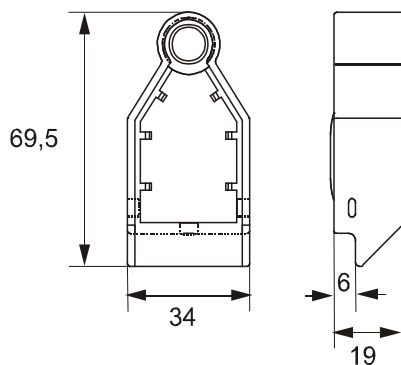
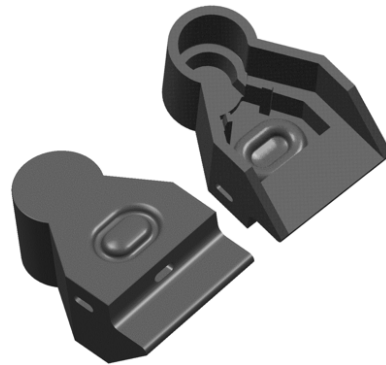
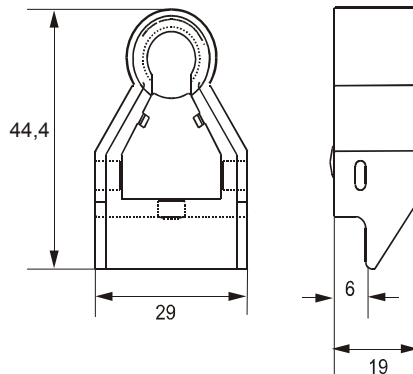

OSE DIAGNOSTIC TOOL

Product description

The DiagnOSE OSE-A 1010 is a tool to ease analyzing malfunctions of an automatic driven door. With the DiagnOSE it is easy to determine if a malfunction of a door is caused by an operation fault in the door control unit or in the safety edge.



Function

The DiagnOSE OSE-A 1010 is connected between the door control unit and the safety edge. On the one hand the OSE-A 1010 sends an enable signal to the door control unit, on the other hand it analyzes the signals coming from the safety edge.

The user can test the function of the door control unit by pressing the button for a short time. The door control unit receives signals identically to pressing the safety edge by normal operation.

Analyzing the signals coming from the safety edges the OSE-A 1010 can decide if the malfunction is caused by the transmitter, receiver or the rubber profile. Additionally you receive information about the current light intensity level of the safety edge.

Connection

The OSE-A 1010 is connected to the junction box or directly to the control unit / door control. The direct connection of the sensors to the control unit / door control is interrupted and conducted through the OSE-A 1010 instead.

The grey cable is connected to the control unit / door control instead of the sensors. The disconnected sensors are connected to the black cable then.

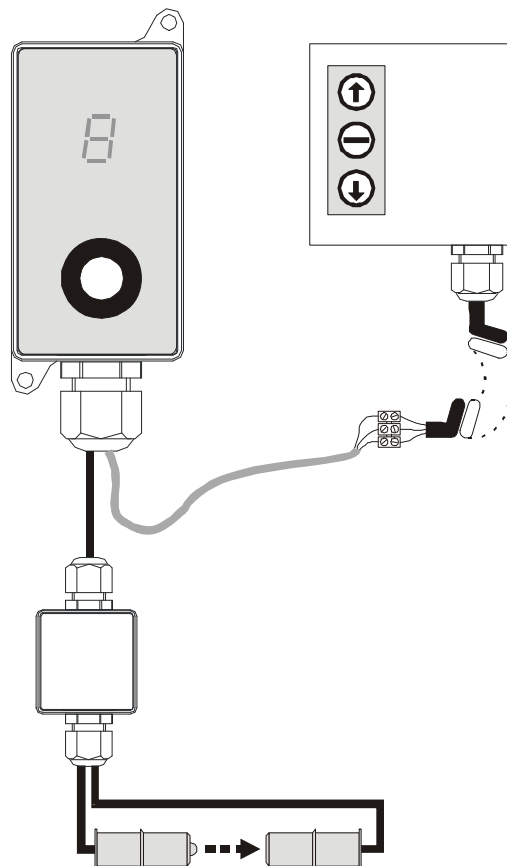

OSE DIAGNOSTIC TOOL

Operation

The unit is activated with a pushbutton.

When pressed shortly, the unit checks the control unit / door control. When pressed for 2 seconds, the unit checks the function of the sensors.

For a complete diagnostics, the control unit / door control is tested by pressing the button shortly at first. After pressing the control unit / door control should actuate and release.

Then the button is pressed for 2 seconds. and the sensors are tested. After 3 seconds the display will show the result. If it only shows a number, the sensing edge works correctly.

Displays

The result of the test is displayed about 5 seconds. If the sensing edge is not working correctly, the

display alternates between „E“ and a number from 1 to 5 every second.

The result yields details of the possible cause of the error. However, sometimes it is still impossible to locate the cause precisely.

Display of an error	
E1	transmitter
E2	receiver
E3	receiver or rubber profile
E4	cable break
E5	short circuit
Display transmitter power	
1,2	perfect
3,4,5	good
6	bad

PNEUMATIC SWITCHES – DW

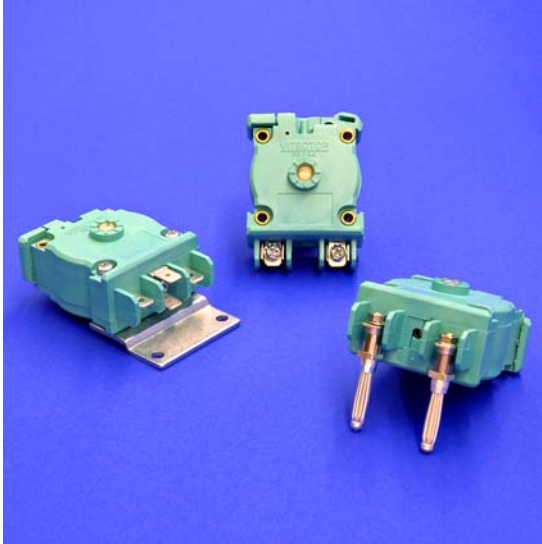

Kinds of contacts:

- S = Normally open contact
- O = Normally closed contact
- W = Change over contact

Pneumatic switches - DW

Designation	ID-No.	Remark
DW 2S-100	10005733	round connector plugs 90°, NOC
DW 2O-100	10005859	round connector plugs 90°, NCC
DW 3S-100	10005652	screw type connectors, NOC
DW 3S-200	10005688	screw type connectors, NOC, in enclosure
DW 3S-300		screw type connectors, NOC, in big enclosure
DW 3O-100	10005713	screw type connectors, NCC
DW 3O-200	10005687	screw type connectors, NOC, in enclosure
DW 3O-300		screw type connectors, NOC, in big enclosure
DW 3W-420	10005797	screw type connectors, NOC/NCC change-over contact, in enclosure
DW 3W-220	10005795	screw type connectors, NOC/NCC change-over contact, in enclosure
DW 5S-100	10005856	6,3 mm flat connector type, NOC
DW 5O-100	10005857	6,3 mm flat connector type, NCC
mounting kitt *	10005918	small mounting angle and 2 pieces M3x25 screws

* = this part is equipped as standard by the DW-3W 420

PNEUMATIC SWITCHES – DW

Technical data

General data	
Diaphragm material	0.3 mm EPDM (-30 °C to +150 °C)
Weight	55 g
Dimensions	55 mm x 45 mm x 33 mm
Contact loads	220 V, 0.5 A
Number of operations	max. 10/sec
Response sensitivity	0.2 to 50 mbar
Standard setting	3 mbar
Mechanical resistance	200 mbar
Ventilation screw	Factory preset open, tighter setting available on request
Types of Housing	21 D 12 plastics grey, other types on request

Mounting Possibilities

After the redesign of the airwave switch housing, there are different ways of mounting the switch to the position needed. By Ø 4 mm hollow rivets the housing of the airwave switch, that is leveled on one side (not for changeover-contact), can be mounted by M3 screws directly on to a mounting plate.

The pitch of the Ø 3,3 connection holes is the same as on the old airwave switch series. Thereby all mounting angles, developed for the old switch, can still be used for the new switch.

Additionally the new housing offers the possibility of mounting it to a DIN rail.

Connectors

The electrical connectors of the airwave switch have changed to 6,3 mm flat connectors. Additionally versions with screw type terminals and round plugs are available.

PNEUMATIC SWITCHES – DW

Drawings

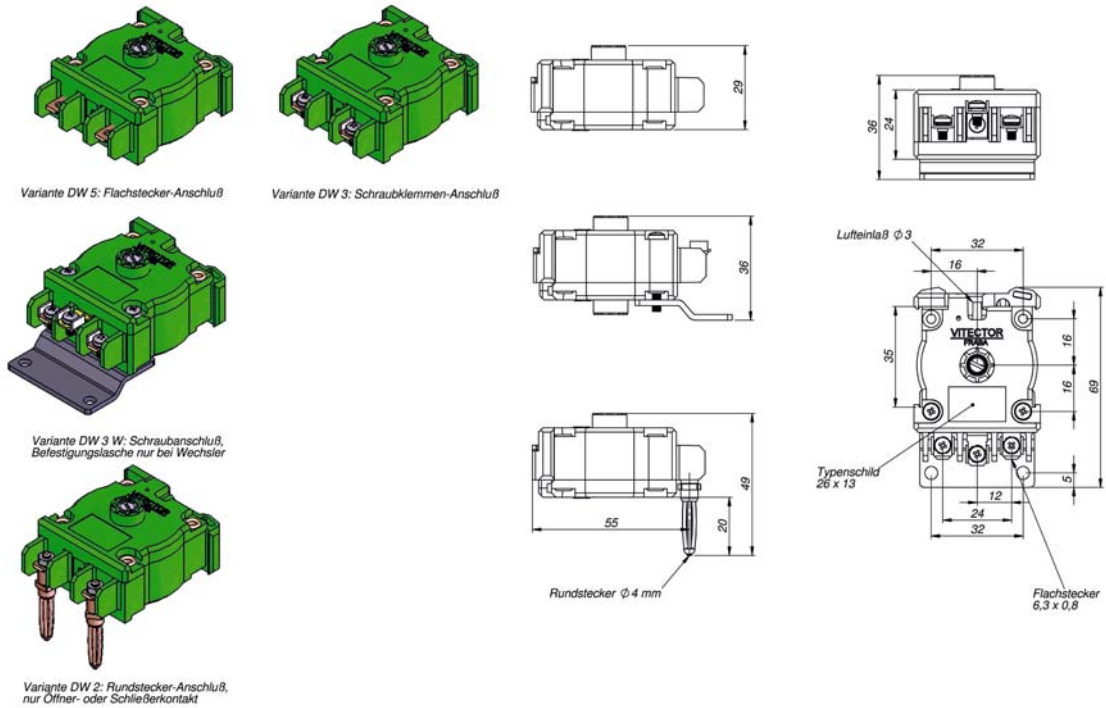

Dimension IP65-Housings

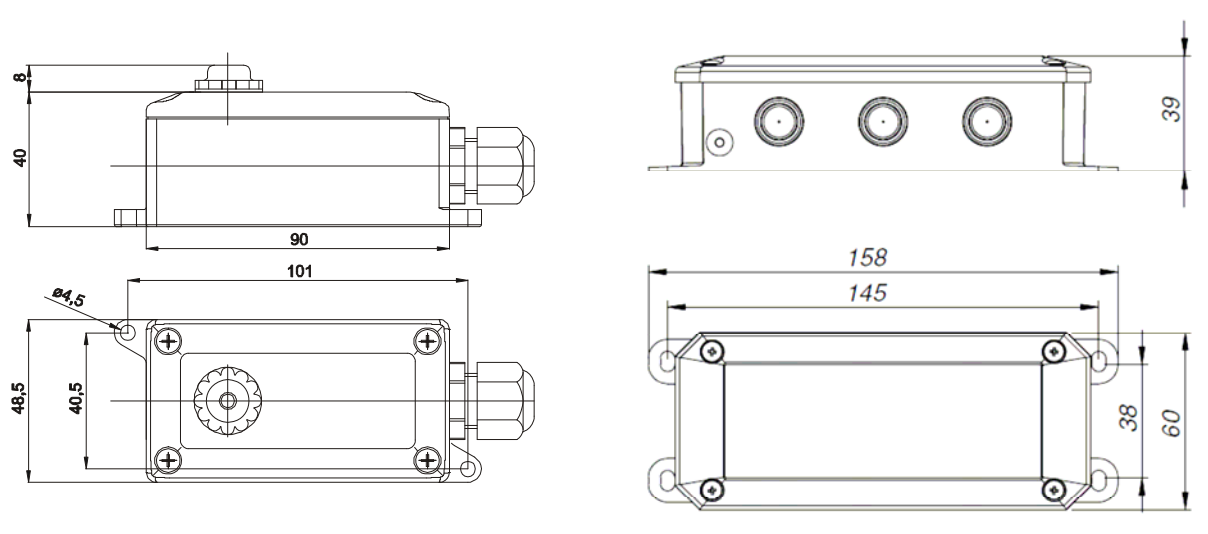

Housing IP65, Type: 200

Housing IP65, Type: 300

PNEUMATIC SWITCHES – DW

Adjustment diagrams

The first figure shows the influence of the contact gap on the response sensitivity. The range, over which the sensitivity was measured, covers typical values for DW switches.

The lower figure shows the influence of the ventilation on the response sensitivity, measured with a position of the adjusting screw to 4 divisions.

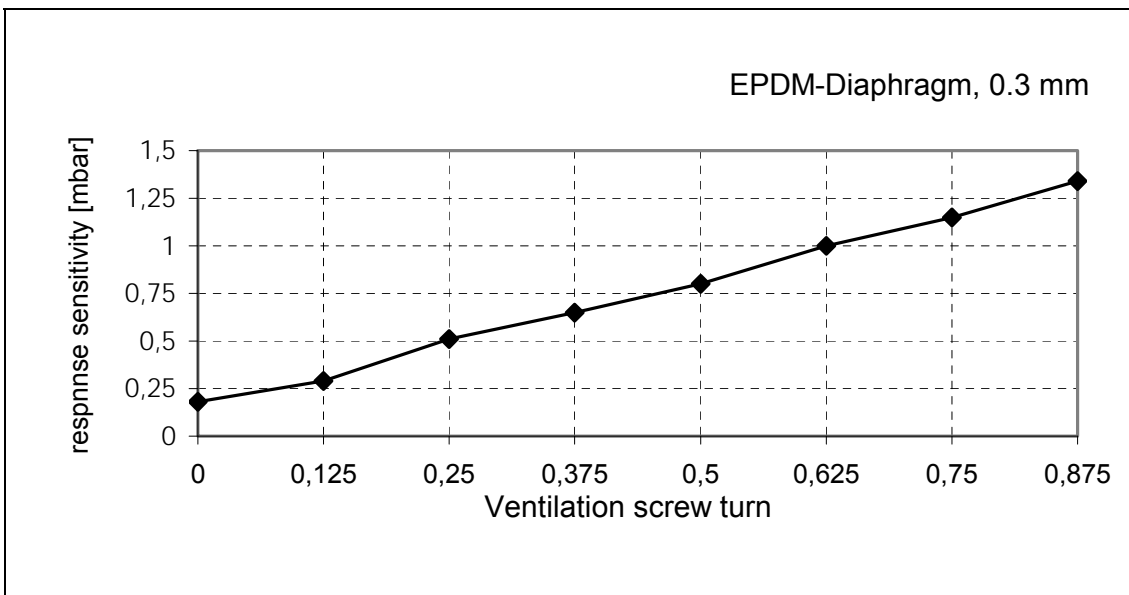
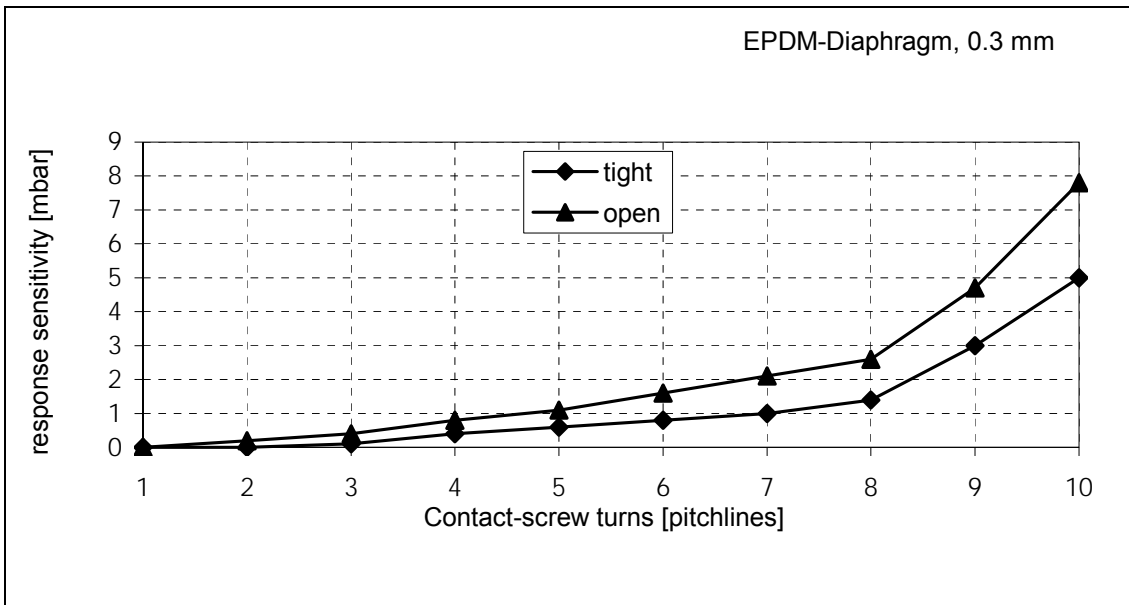

SIGNAL SOURCE

Signal Source

Designation	ID-No.	Remark
DW-T	10003337	Push Button DT

Airwave Push Button

Type DW-T

Pushbutton Ø 42 mm, Installation depth ca. 45 mm

(Signal Hose output 180°)

Monting with locknut and sealing

Delivery without Signal Hose

Bellow entirely sealed

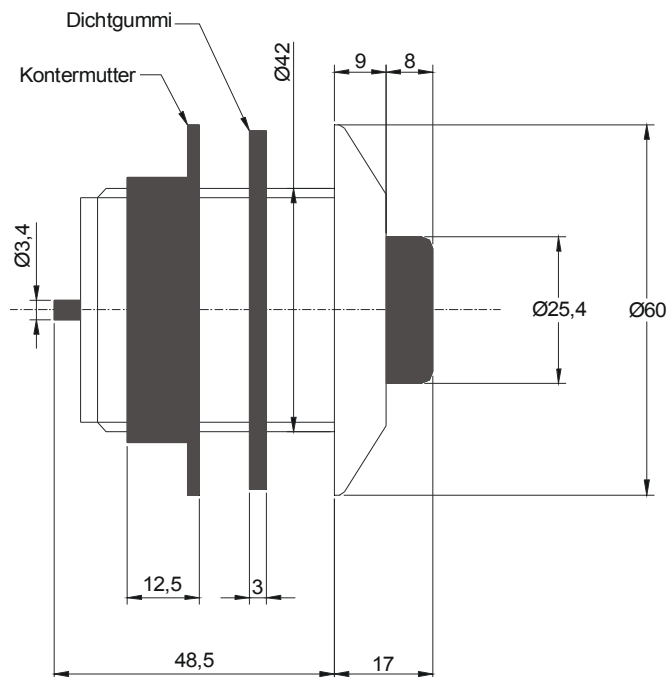

SIGNAL SOURCE

Signal Source Rubber Profiles

Designation	ID-No.	Remark
21 Z 58	79221400	Profile (NBR, oil resistant)
OSE-P 25 75 00	75142030	Door Profile with Sealing Lip

Drawing Rubber Profile

21 Z 58, Profile (NBR, oil resistant) (Roll Length 25 m) OSE-P 25 75 00 (Roll Length 25 m)

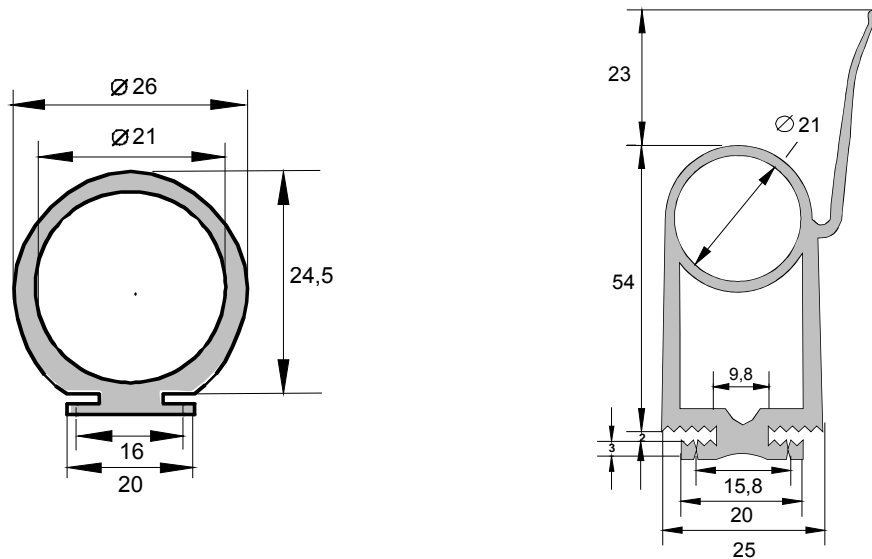

Technical Data Rubber Profile

General Data	21 Z 58	OSE-P 25 75 00
International marking	NBR	EPDM (APTK)
Chemical marking	Nitril-Kautschuk	Ethylen-Propylen-Ter-Polymer
Rebound elasticity at 20 °C	Satisfying	Good
Resistance against permanent deformation	Good	Good
Generally weatherproof	Good	Excellent
Ozone-resistance	Satisfying	Excellent
Oil-resistance	Excellent	Low
Fuel-resistance	Good	Low
Chemical solvent-resistance t	Good by parts	Low to Satisfying
General resistance against acids	Satisfying	Good
Temperature resistance		
c) Short-term	- 40 °C to +150 °C	- 50 °C to +170 °C
d) Long-term	- 30 °C to +120 °C	- 30 °C to +140 °C

PNEUMATIC SWITCH - ACCESSORIES

Pneumatic switch - accessories

Designation	ID-No.	Remark
21 Z 56	79221956	End plug
21 Z 60	79221960	Connector plug
21 Z 59	79221959	Connector plug
21 Z 61	79221961	Connector plug
21 Z 62	79221962	Connector plug
21 Z 49	79221949	End plug
21 Z 46	79221946	Connector plug
21 Z 55	79221955	Angle connector plug
ALU - 2509	79221000	Alu-C Profile

Drawings

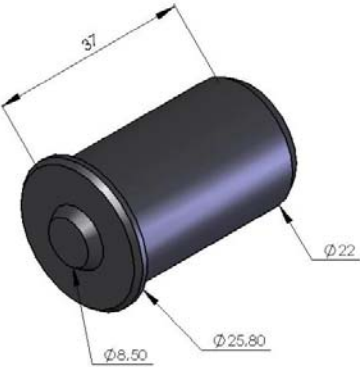
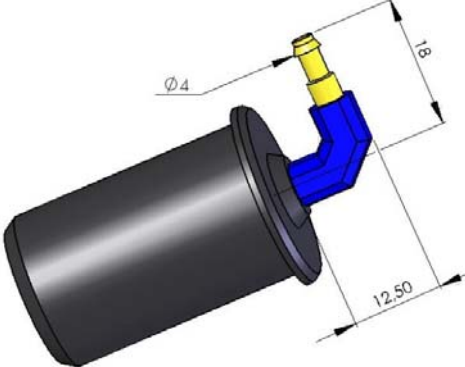
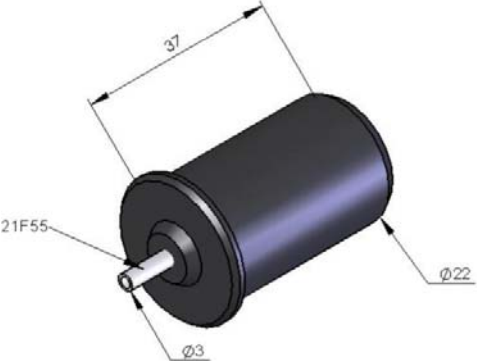
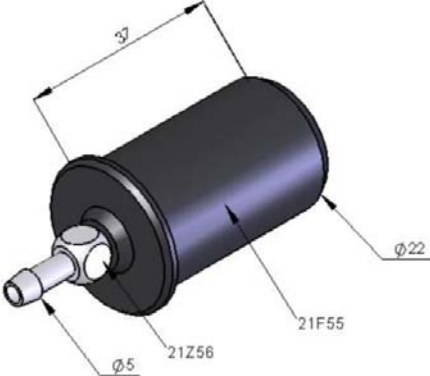
<p>21 Z 56, End plug</p> 	<p>21 Z 59, Connector plug</p> 
<p>21 Z 60, Connector plug</p> 	<p>21 Z 61, Connector plug</p> 

PNEUMATIC SWITCH – ACCESSORIES

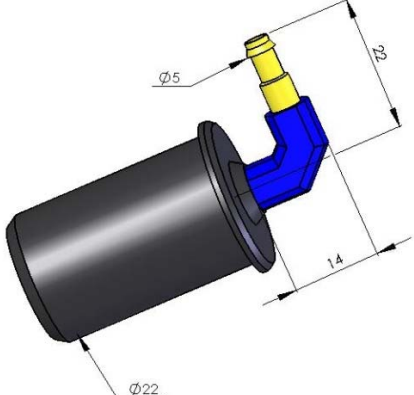
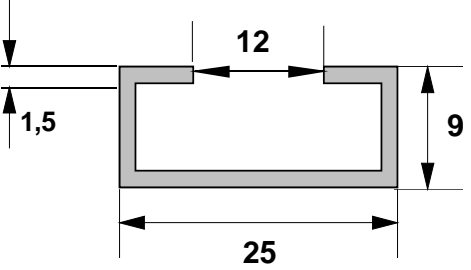
21 Z 62, Connector plug	21 Z 65 , Alu-C Profile (max. length 2.5 m)
 <p>A 3D perspective view of a connector plug. It consists of a black cylindrical base with a diameter of $\varnothing 22$. A blue plastic fitting is attached to the side of the base, extending 14 units from the base's centerline. A yellow plastic plug is inserted into the blue fitting, with a diameter of $\varnothing 5$ and a length of 22 units.</p>	 <p>A cross-sectional diagram of an Alu-C profile. The profile is U-shaped with a total width of 25 units and a height of 9 units. The top flange has a thickness of 1.5 units. The distance between the inner vertical walls is 12 units.</p>

PNEUMATIC SWITCH – ACCESSORIES

Accessories (Signal hoses / Coil cords)

Designation	ID-No.	Remark
PVC-hose 2 x 4 mm	79220000	
Silicone hose 2 x 5 mm	79220001	
21 F 50 F	79220451	T-connector
21 F 53	79220453	Angle connector
21 F 07	79220407	Connector
21 F 55	79220455	Connector
Silicone hose 4 x 7 mm	79221002	
21 Z 15	79220616	Reducing piece, 4 x 7 / 2 x 4 mm
21 F 57	79220457	Angle-reducing piece, 4 x 7 / 2 x 4 mm
21 Z 80	79240680	Connector for housing, 4 x 7 / 2 x 4 mm

Drawings

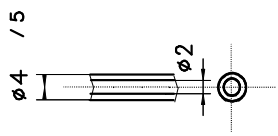
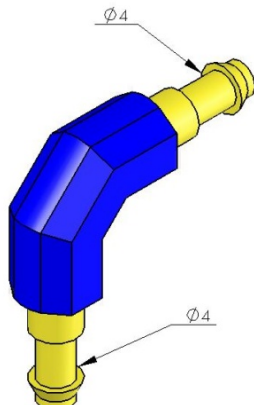
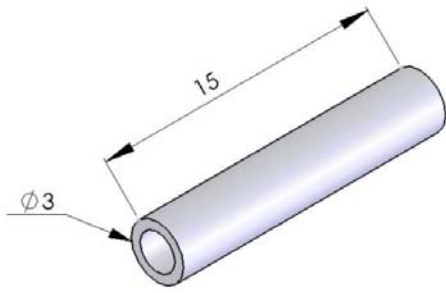
<p>PVC-Silicone hose ($\varnothing 2 \times 4 / 2 \times 5$ mm)</p> 	<p>21 F 53, Angle-connector $\varnothing 2 \times 4$ mm</p> 
<p>21 F 07 / 21 F 55, Connectors $\varnothing 2 \times 4$ mm</p> 	

PNEUMATIC SWITCH – ACCESSORIES

Drawings Signal hoses / Coil cord

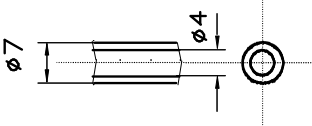
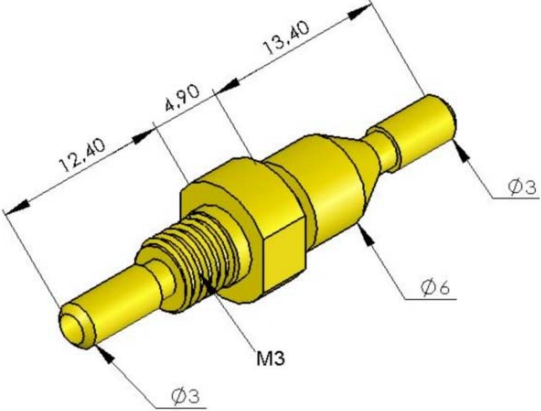
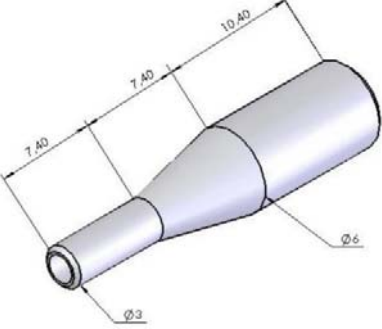
<p>Silicone hose $\varnothing 4 \times 7$ mm</p>	<p>21 Z 80, Connector</p>
	
<p>21 F 15, Reducing piece ($\varnothing 2 \times 4$ to $\varnothing 4 \times 7$ mm)</p>	
	
<p>Coil cord, 5×0.5 mm²</p>	

RAYTECTOR

Product descriptions

RAYTECTOR is single-beam, type 2 light barrier (in accordance with DIN IEC 64196-2) used as a safety measure at power operated gate installations. It is composed of a light transmitter (RAY-T1000) and a light-receiver (RAY-R1000).



An interruption of the light beam initiates a signal between transmitter and receiver which interrupts the movement of the power operated gate. In combination with the certified (type 4 BG) control units OSE-C 2323 or OSE-C 2324 the RAYTECTOR constitutes a system according to EN 954-1, safety category 3.

The pull-in protection RAYTECTOR is suitable for absolute fitting dimensions between 1.5 to 10.5 m.

Transmitter and receiver are inserted in compound-filled plastic housings. The respective 10.5 m length of the connector cables allow the direct connection to the control unit.

Descriptions of function

Any interruption of the light beam, caused by external light as well as faults in electrical components (including the connection to the control unit) will be detected safely.

This is guaranteed through the coupling of the transmitter-receiver system. The transmitter emits pulsed infrared light which can be detected by the receiver belonging exclusively to it.

After the detection of the transmitter light the receiver via signaling line switches off the transmitter. The emitting of the light beam stops. This status is also detected by the receiver and the transmitter will be switched on again after a short delay. The resulting dynamic signal is evaluated by the control unit. With the elimination of the signal the control unit turns off immediately and stops the gate movement.

The transmitter system determines the required transmitting intensity and adjusts it according to transmitter range and environmental conditions. The bicolor LED on the front of the receiver indicates the operating status.

Requirements

At power operated gates – when they are not operating in dead man's status – must conform to the safety measures outlined in EN 12453 which requires that persons shall not be lifted or endangered by squeezing or shearing-off at pull-in points. The EN 12453 offers contactless-installations which will interrupt a gates movement. The protection provided must at a minimum fulfill at least the requirements of safety category 2 of EN 954-1 and to satisfy the optical demands of DIN IEC 61496-2.

The RAYTECTOR pull-in protection in combination with an external or integrated OSE control unit provides a universally safety installation with valid conformity to standards.

RAYTECTOR

Range of applications

At gates with surfaces that have the potential for pulling people in (e. g. rolling gates, grating type) a protection installation is prescribed imperatively to prohibit the dead man's wiring in- and outside.

Gates which enable the clinging to (e. g. hinge swellings at rolling gates; bracings at sectional gates), which allow a passenger lift upon the

lower head angle or gates where the pull-in cleft between gate plate and winding traverse and between winding traverse and e. g. garage ceiling (if not covered by a rolling box) is lower than 2.5 m and therefore in intervention range have to be protected too at the respective risk-areas.

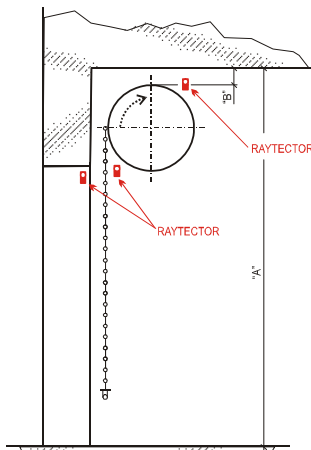

Mounting status at rolling gates (grating type). Additional RAYTECTOR necessary under ceiling only, if:
 "A" < 2.500 mm and concomitant
 "B" < 8 cm (with rolled-up gate)

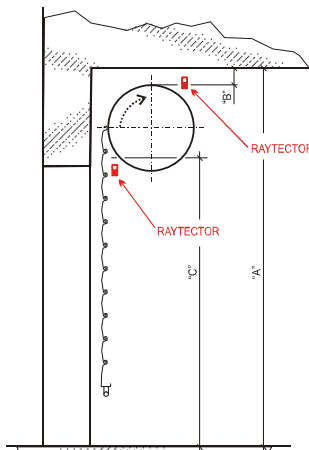

Mounting status at rolling gates. Protection of pull-in area with RAYTECTOR, if: "C" < 2.500 mm. Additional RAYTECTOR under ceiling, if:
 "A" < 2.500 mm and concomitant
 "B" < 8 cm (with rolled-up gate)

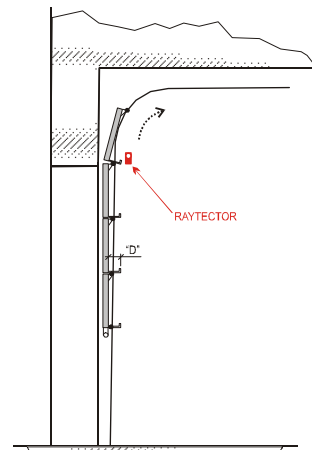

Mounting status at sectional gates. Protection with RAYTECTOR necessary, if brace depth "D" allows a gripping to it or an ascending of persons.

Designation	ID-No.	Remarks
RAY-S 1100	74013000	Set, composed of: 1 Raytector - Transmitter, 1 Raytector - Receiver
RAY-S 1101	74013001	Set, composed of: 1 Raytector - Transmitter, 1 Raytector - Receiver 2 assembly angles
RAY-S 1102	74013004	Set, composed of: 2 Raytector - Transmitter, 2 Raytector - Receiver 4 assembly angles, 1 OSE-C 2300
RAY-A 0010	74010001	Set of assembly angles
OSE-C 2300	75111023	Control unit

RAYTECTOR

Distance to risk-areas

The light barriers have to be mounted in an adequate distance from the risk-areas to make sure that the moving gate will be stopped before the risk-area will be reached. A distance of about 150 mm from the shearing-off area (along the

travel range of the gate) is normally adequate, but can be adjusted accordingly for high speed gates.

With low mounted light barriers an overlapping of the protection installation may not be possible.

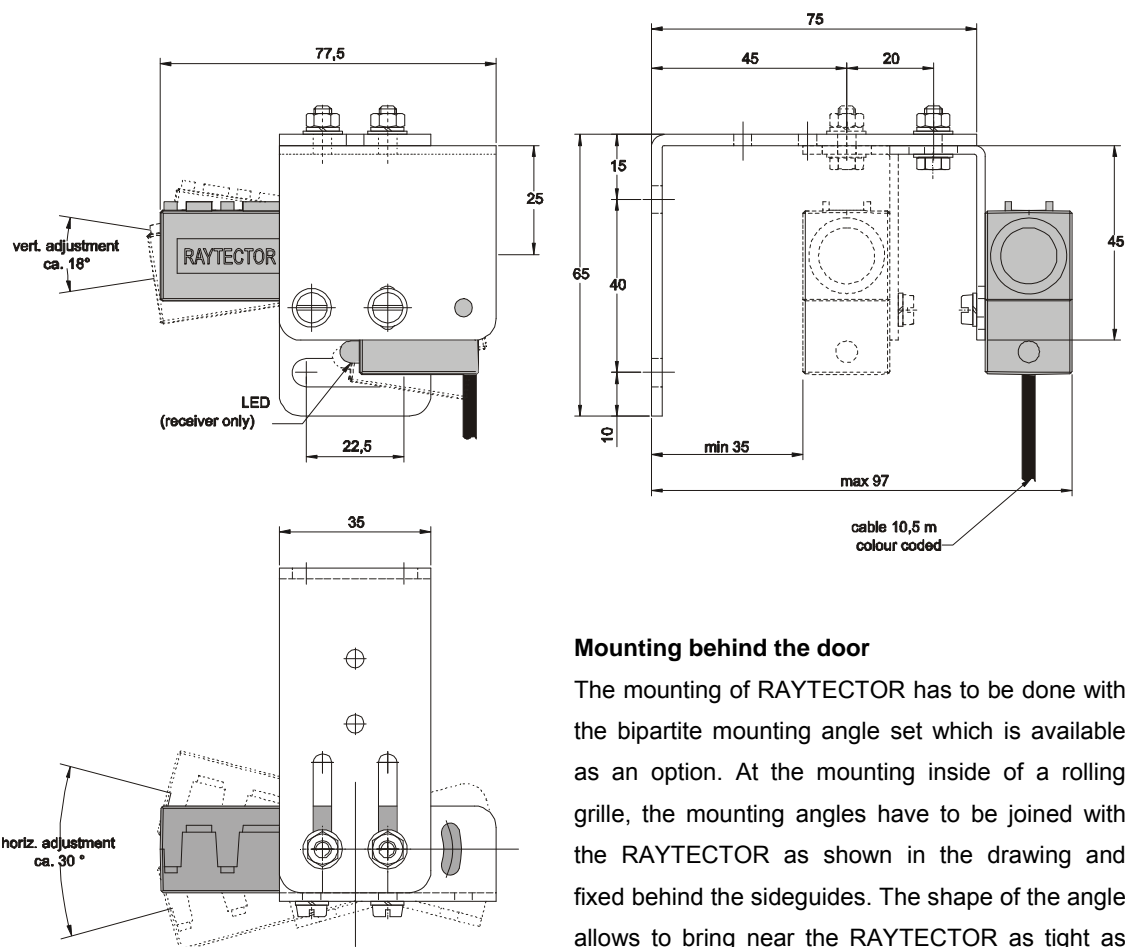

Mounting behind the door

The mounting of RAYTECTOR has to be done with the bipartite mounting angle set which is available as an option. At the mounting inside of a rolling grille, the mounting angles have to be joined with the RAYTECTOR as shown in the drawing and fixed behind the sideguides. The shape of the angle allows to bring near the RAYTECTOR as tight as possible to the moving curtain.

RAYTECTOR

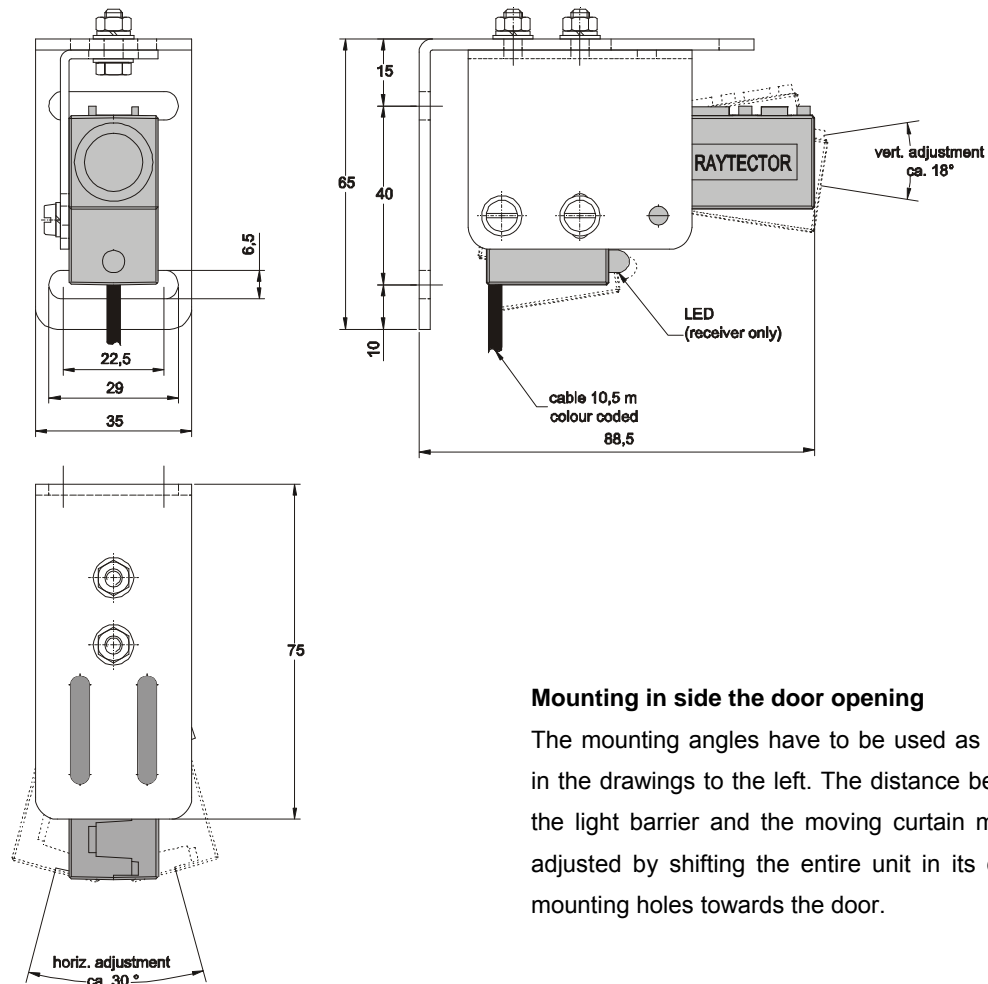

Mounting in side the door opening

The mounting angles have to be used as shown in the drawings to the left. The distance between the light barrier and the moving curtain may be adjusted by shifting the entire unit in its oblong mounting holes towards the door.

Electrical connection

The pull-in light barrier RAYTECTOR can normally be run with a control unit (e. g. OSE-C 2323 or OSE-C 2324). If the applied control unit OSE has enough inputs as required and additionally for the interruption of endangering gate movings, the application of an external control unit is not necessary. Please follow the operating instructions of the control unit. The cable length of 10.5 m is designed for maximum

range and the side-inverted mounting of two transmitters and two receivers. The leads of RAYTECTOR have to be assembled in the housing of the control unit and connected according to the colors at the clamps bn (brown), we (white) and gn (green) of the control unit.

RAYTECTOR

Connecting RAYTECTOR (clamp1 to 6)

The brown and white leads of the lights barriers must be connected parallel to clamps 1 (brown) , 2 (white). The green leads must be connected separately to the clamps 4 and 6. With the connection of only one light barrier the clamps 5 and 6 have to be bridged. With the connection of additional RAYTECTOR-systems a different control unit is required. Release contact (NCC) (clamps 33 - 34). The relay contact between the

clamps 33 and 34 is closed in normal operation status of the "Pull-in Protection". It opens at actuation or faults and interrupts the release circuit of the gate.

Voltage supply (clamp 33 - 34)

OSE-C 2324: 24 V DC \pm 20% or 24 V AC \pm 20%

OSE-C 2323: 230 V AC \pm 20%.

Connection to control unit OSE-C 2323

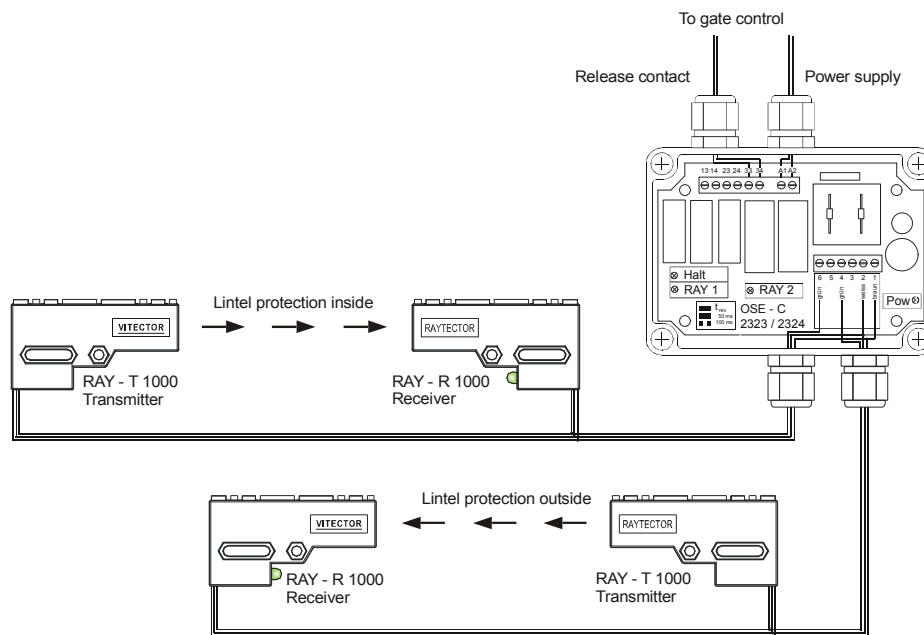

Dimensional drawing of RAYTECTOR-housing

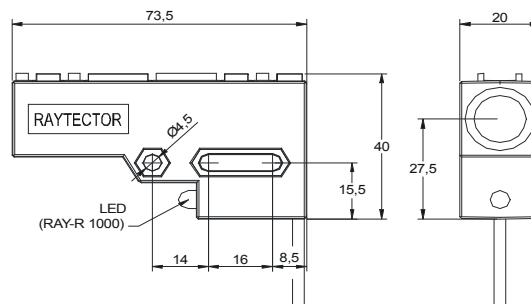

RAYTECTOR

Technical data RAYTECTOR

General Data RAYTECTOR, consist of RAY-T 1000 and RAY-R 1000	
Protection area range	1.5 ... 10 m
Beam number	1 beam
Safety category	Light barrier type 2 according to EN 954-1 and EN 61496-2
Protection class	Housing IP 54
Housing material	Acrylnitril-Butadien-Styrol, black
Housing dimensions	Width: 73.5 mm, Height: 40 mm, Depth: 20 mm
Connector cable	10.5 m, 3-lead, color coded
Operation temperature	-10 °C to +55 °C
Ambient humidity	15...95%
Supply voltage	12 V DC (+10 % / -10 %)
Power consumption	max. 60 mA

Operating status/Fault diagnosis/trouble shouting RAYTECTOR

Indication	Operating status	Possible cause	Remedy
LED green	O. K.		
LED red	Light barrier actuated or not ready for working	Light beam interrupted Incorrect orientation Lenses soiled RAY-T 1000 or RAY-R 1000 defective	Correct orientation according to "Operating Instructions" Clean lenses Change the respective device
LED out	Light barrier without power supply	Wiring defective Control unit defective or without power supply	Check wiring Check power supply; change control unit

RAYTECTOR

Technical data control units

General Data OSE-C 2323 / OSE-C 2324	
Safety category	Cat. 3 developed according to DIN EN 954-1
Protection class	Housing IP 65 (DIN VDE 0470)
Housing material	Polycarbonate, RAL 7035 grey, transparent cover
Housing dimensions	Length: 94 mm, Width: 130 mm, Height: 60 mm (without PG-joints)
Fitting position	Any alignment
Operation temperature	-20 °C to +55 °C
Supply voltage	OSE-C 2323: 230 V AC \pm 20 % OSE-C 2324: 24 V DC \pm 20 % oder 24 V AC \pm 20 %
Frequency range	48 Hz - 64 Hz
Power consumption	max. 7 VA
External fuse	0.2 A slow (not contained in appliance)
Transient voltage suppression	III/4 kV according DIN VDE 0110, part 1
Soiling category	Cat. 2 according to DIN VDE 0110, part 1
Cyclic duration factor	100 % CDF
Weight	OSE-C 2324: 0.36 kg; OSE-C 2323: 0.5 kg
Response time	max. 16 ms

Indications and terminal assignments OSE-C 2323 / OSE-C 2324	
LED "Pow"	LED green – Power on, ready for working
LED "Halt"	LED yellow – Slack cable -/ wicked door switch closed (without usage)
LED "OSE 1"	LED green – RAYTECTOR at terminal 4 - O. K.
LED "OSE 2"	LED green – RAYTECTOR at terminal 6 - O. K.
Input contacts	
1, 2, 3, 4, 5, 6	Signal transmitter 1, Signal transmitter 2, Slack rope switch chain
A1, A2	Power supply
Output contacts	
13, 14	Slack cable -/ wicked door switch, (NCC), (without usage)
23, 24	Reverse contact, (NCC), (without usage)
33, 34	Output Relay RAY 1 / RAY 2, (NCC), (stops door movement)

FLASHENTRY

Product description

The FLASHENTRY allows activation of an automatic gate or door by flashing a car's headlights.



Thus personnel, customers or suppliers are able to open a door during the office hours without leaving the vehicle. The device is activated by the headlight flasher and does not need any actions from the inside of the building. The complicated use of remote controls, which are often lost or with faulty batteries is no longer necessary.

The FLASHENTRY can be installed in a few assembly steps to each gate and works with already existing radio receivers, too. By using a radio transmitter combined with a battery-powered voltage supply no additional coil cords or signal lines are necessary.

Description of the functions

The FLASHENTRY is mounted to a sectional door, where the light sensor can be illuminated with the headlights. Optionally several further light sensors can be installed at different positions at the gate or at a wall.

The operation of the headlight flasher at the car is recognized and processed by the FLASHENTRY. If a defined number of light pulses is recognized, the device activates the internal transmitter and sends a signal to the door control.

The FLASHENTRY is compatible to all conventional radio receivers in door controls. The user can set different operating parameters like the number of light pulses and the light sensitivity

Features

- Cordless due to the radio transmission from the FLASHENTRY to the door control
- Usable with all conventional door controls
- Easy and quick installation at the lower section of the door
- Only a small light sensor is visible from the outside
- Tuneable for different light sensitivities
- Changing of the number of required light pulses from 2 to 5 to open door
- Insensitive against light reflections and sun light. Only light pulses from the car lead to an activation of the unit

FLASHENTRY

Range of application

The FLASHENTRY is suited for all frequently used doors, which are accessible for certain persons, for example:

- car dealer
- repair garages
- shippers and parcel services



Housing dimension

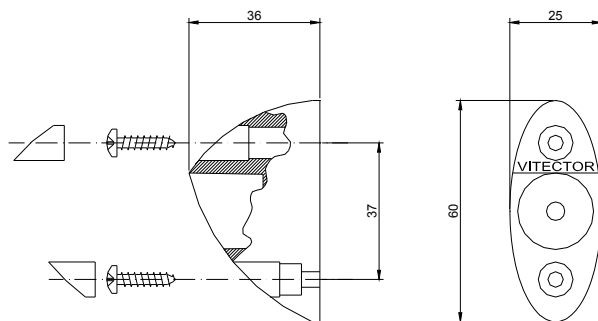
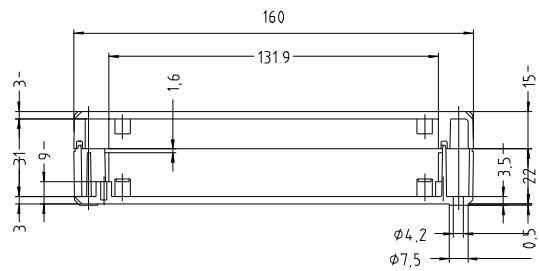
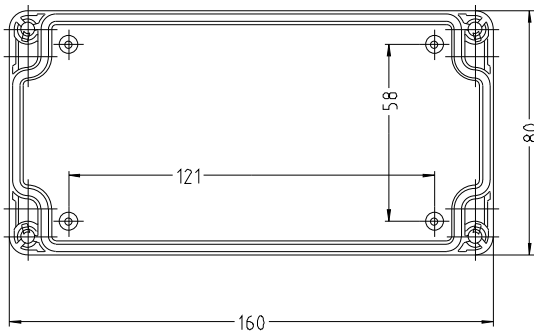

FLASHENTRY

Assembly

The FLASHENTRY unit is mounted with the mounting screws at the inside of the door. The light sensors can be mounted at the outside of the door.

For the installation execute the following steps:

Find out the height of the car light spot

The light sensor must be adjusted to the height of the car head lights, which are to activate the FLASHENTRY unit.

As a default value you can use a height of 50 to 60 cm for limousines. For trucks or sports cars this value can change plus or minus 30 cm. The side-wise offset is about 50cm from the center of the lane according to the generated light spot from the car.

Installation of the light sensor

Depending on the scope of the delivery 1 or 2 light sensors are mounted at the outside of the door.

The FLASHENTRY unit is installed inside at the height of one of these sensors (see 3.), so there must be enough space at the inside.

A drilling through the door ($\varnothing=9\text{mm}$) is required to lead the sensor cable to the FLASHENTRY unit.

Use the mounting screws then to fasten the light sensor.

In case of doubt regarding the mounting position of the light sensor, check the position of the light spot at the door with a test car.

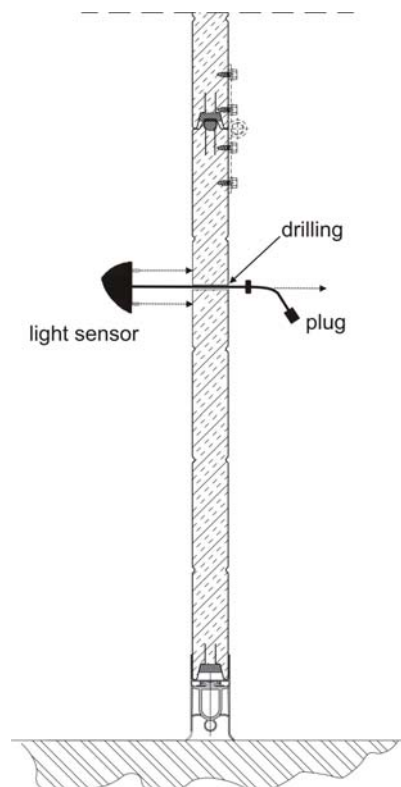

FLASHENTRY

Attaching the FLASHENTRY unit

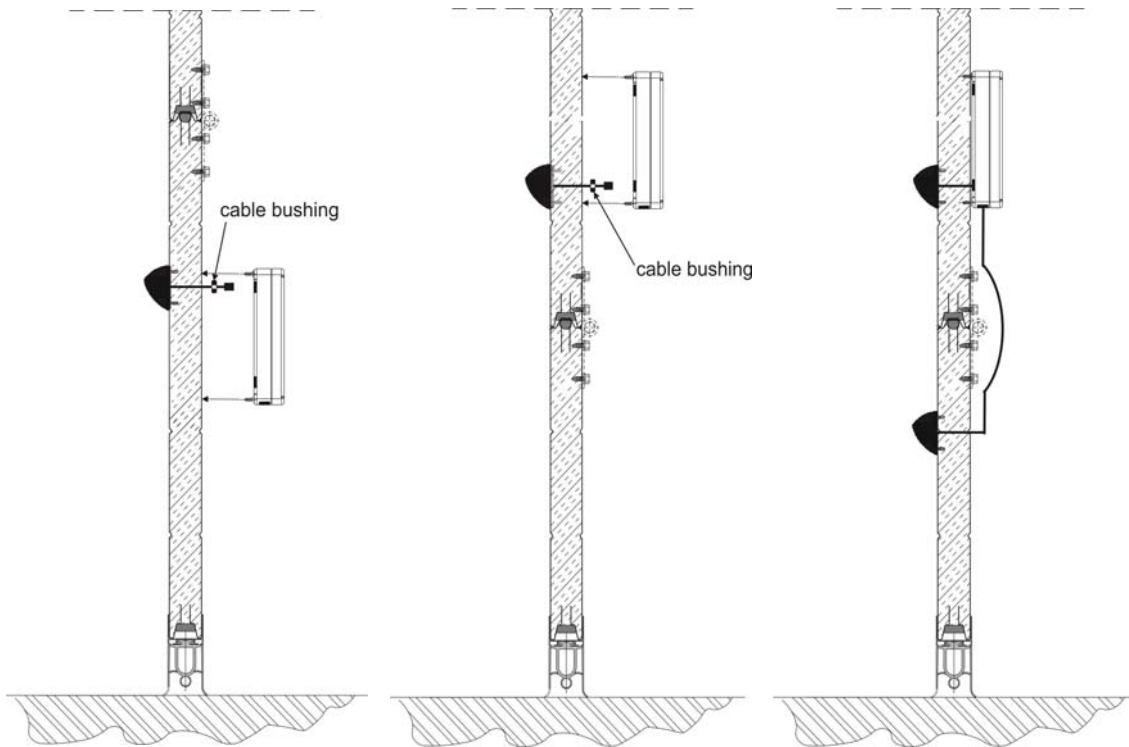

The FLASHENTRY unit is mounted at the height of one of the sensors. Screw off the top cover for an easier handling.

At first put a punched rubber cable grommet to the sensor cable with the bore hole pointing at the plug.

Then pull the sensor cable through the hole at the back side of the FLASHENTRY case. Additionally, plug the grommet in the hole to seal it.

Now pull the sensor cable from the front side through the cut-out at the PCB and mount the case with the mounting screws.

If there is another light sensor mounted, lead the sensor cable at the inside of the door to the drilling at the side of the case and use the second grommet to fix it to the case.

If there is only one light sensor, seal the drilling at the side of the case with the third, non-punched grommet.

FLASHENTRY

Inside view

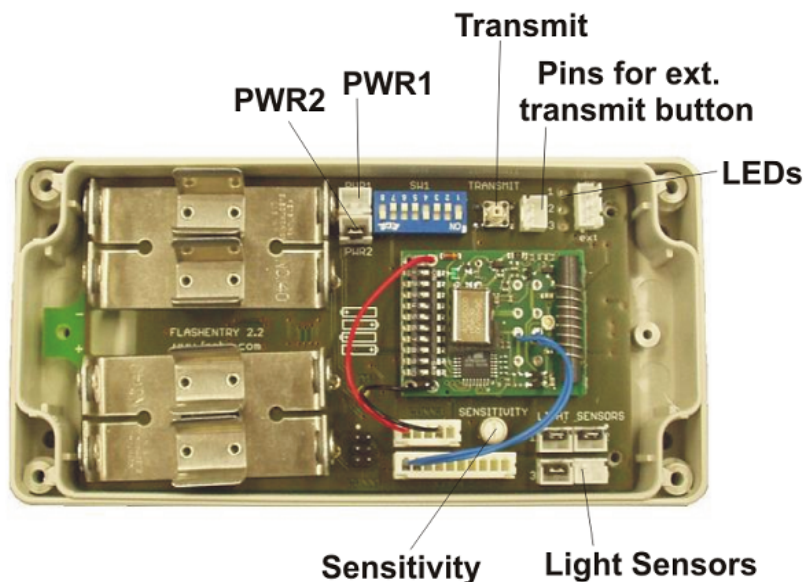

Description of the components

Description	Function
TRANSMIT	Pushbutton to trigger the transmission. An external button can be connected to the corresponding pins. If no external button is connected, the pins must remain free.
PWR1	Connection pins for an external power supply. Without an external power supply these pins must remain free.
PWR2	Connection pins for an external on/off switch. Without an external on/off-switch these pins must be bridged.
DIPs	DIP switch to set the functional parameters.
LED ext	Connection pins for external function LEDs. Without external function LEDs these pins must remain free.
LED1 (red)	Rising light pulse identified.
LED2 (green)	Falling light pulse identified.
LED3 (yellow)	Power On
Sensitivity	Potentiometer to set the sensitivity. Decrease the sensitivity by turning it clockwise (batteries on the left).
Light Sensors	Connection pins for the light sensors. Unused pins have to be bridged.

FLASHENTRY

FLASHENTRY articles

Article	Article number	Description
FLA-C 5001	10001310	FLASHENTRY control unit with transmitter and receiver
FLA-A 130	10000495	FLASHENTRY light sensor with 300mm cable
FLA-A 170	10000497	FLASHENTRY light sensor with 700mm cable

Technical data FLASHENTRY

Voltage supply	4x1,5V AA cells
Power consumption	average 0,2 mA, depending on the used radio system
Battery life time	about 1 year for standard AA cells
Operating temperature	-10°C to +50°C
Dimensions control unit	160 x 80 x 37 mm
Dimensions light sensor	50 x 25 x 35 mm
Protection class	IP54
Connections	1x 2wire for external button 1x 2wire for external On/Off-switch 1x 2wire for external power supply 4x 2wire for up to 4 light sensors
Accessories	Light sensor with cable 300mm or 700mm Mounting angle for light sensors

ENTRYSENSE

Product description

On wicket doors in sectional door panels a device has to be fitted to prevent the power operation of the door while the door is not in its locked position. The door contact ENTRYSENSE is a redundant, magnetic non-contact sensor specifically designed for flush mounting inside an industrial doors wicket door frame. The operational safety is achieved by the use of an assembly of two serial reed-contacts, whose operating conditions can be monitored by an external device.



The magnet (above left) of the ENTRYSENSE is mounted in the door leaf, the switch assembly (above right) into the door panel. ENTRYSENSE can be used as a normal redundant NO contact, in order to fulfill the normative requirements a dedicated interface is necessary. All door control units the company GfA have this interface on board.

Requirements

Wicket doors in panels of power operated doors have to safely locked in their closed position before any operation of the door. This applies to fully automated doors as well as to doors in deadman mode. A safe contact has to ensure, that the operator does not start with the door is unlocked and stops the motor immediately, as soon as the lock unlatches during operation.

The EN 12453 requires the use of a redundant, fail safe contact, that will detect any internal failure while still keeping its intended function. This sensor must be compliant with the safety category 2 of EN 954-1.

Easy installation

The door contact ENTRYSENSE is installed sheltered within the embrasure of the door. A remaining gap of 8 mm is required.

The cast-on connecting cable is fed from the back side of the sensor through the frame profiles and connected in the spiral cord junction box.

For an easy fine tuning of the magnetic switch after installation or after the door had been in excessive operation, the operating distance may be adjusted easily without dismantling the unit.

ENTRYSense

Technical data

Safety category	2 acc. EN 954-1
Degree of protection	IP 68
operating temperature	-20° C to + 75 ° C
Operating voltage	24 V AC / DC
max. switching capacity	max. 0,5 A
max. vibration	max. 10 g (1 Hz – 20 KHz)
max. operating distance	4 mm

Integrated interface

ENTRYSense is a shared development of FRABA VITECTOR GmbH and GfA Elektromaten.

The interface for the ENTRYSense pedestrian door contact is already on board in the GfA door control units TS 956, TS 961, TS 970 and TS 981. When used in combination with any of those control units ENTRYSense accomplishes the safety category 2.

Connected to any other door control units ENTRYSense remains a redundant normally opened contact.



Operating states

Input voltage		24 V
Output signal	door closed	24 V
Output signal	door open	0 V
Output signal	fault detected	9 V

Dimensions

Mounting Ø	13,5 mm
Mounting depth	9 mm (magnet) 27 mm (switch)
Flap dimensions	18,5 x 37,5 mm (B x H)
Mounting bolts	2 x M4, counter sunk
cable length	3 m
housing color	Black

Dimension

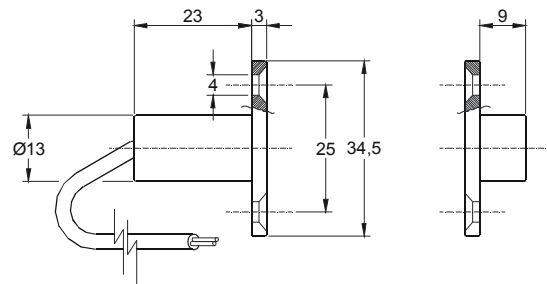

C O N T A C T

VITECTOR GmbH

Carlswerkstraße 13c

D - 51063 Köln

Telephone: +49 (0)221-96213-0

Fax: +49 (0)221-96213-60

Email: info@vitector.de

www.vitector.de

FRABA Inc.

1800 East State Street Suite 148

Hamilton, 08609 NJ

Phone: +1 609-750-8705

Fax: +1 609-750-8703

Email: staff@fraba.com

www.vitector.com

Contact Persons

Alexander Eckhardt +49 (0)221-96213-63

Andre Quaiser +49 (0)221-96213-64

Konrad Machill +49 (0)221-96213-65

Markus Schillo +49 (0)221-96213-67

Rainer Stiepel +49 (0)221-96213-62

Contact Person

Michael Bowne +1 609 7508705

INSPECTION RECORD

Machine / Building project

Used components

	Designation
Control unit	
Rubber-Profile	
Transmitter	
Receiver	
Alu-C Profile	

Maintenance of the safety edge

In the context start-up and regular maintenance of the machine the safety edge should be checked by skilled persons regarding the following points:

1. All affected people must be advised regarding the protection device.
2. The construction has to be in a good condition and refurbished.
3. Any modification of the construction or position of the safety edge can cause dangerous situations and must not be performed without permission of the manufacturer.
4. The door opening has to be kept free from obstacles.
5. Wearing parts
The opto-electronical safety edge (OSE) is designed without wearing parts. Therefore no regular exchange of parts is needed.
6. Inspection of rubber profile
Visible inspection and removal of all dirt on the rubber profile surface and the connectors, to guarantee that no damage has occurred that could affect the intended operation.
7. Visual inspection of the signal transmission
Inspection of the connections to guarantee that no damage has occurred and no modification has been made which prevents the intended operation.
8. Visual inspection of the control unit
The housing has to be closed and should be in a good state. Inspection of the connections to guarantee that no damage has occurred and no modification has been made which prevents the intended operation.
9. Control of markings
Verify that all component labels exist and can be read.
10. Actuation of the signaling element at several positions with standing machine. The sensitivity of the safety edge should be determined over the entire sensing surface. A check of the LEDs in the control unit should be performed.
11. Actuation of the signaling element with moving machine. A stop must be executed. Regarding gates, a reversion must be initiated. The restart of the machine should not be possible until the safety function was restored. The correct functioning of the unit has to be proven through periodic checks and should be documented.